



Old-Growth Again
Restoring Logged Forests
One Tree At A Time



Young Growth – Mature Growth – Old Growth

ASSEMBLY INSTRUCTIONS FOR 3FT TRESTLE BENCH

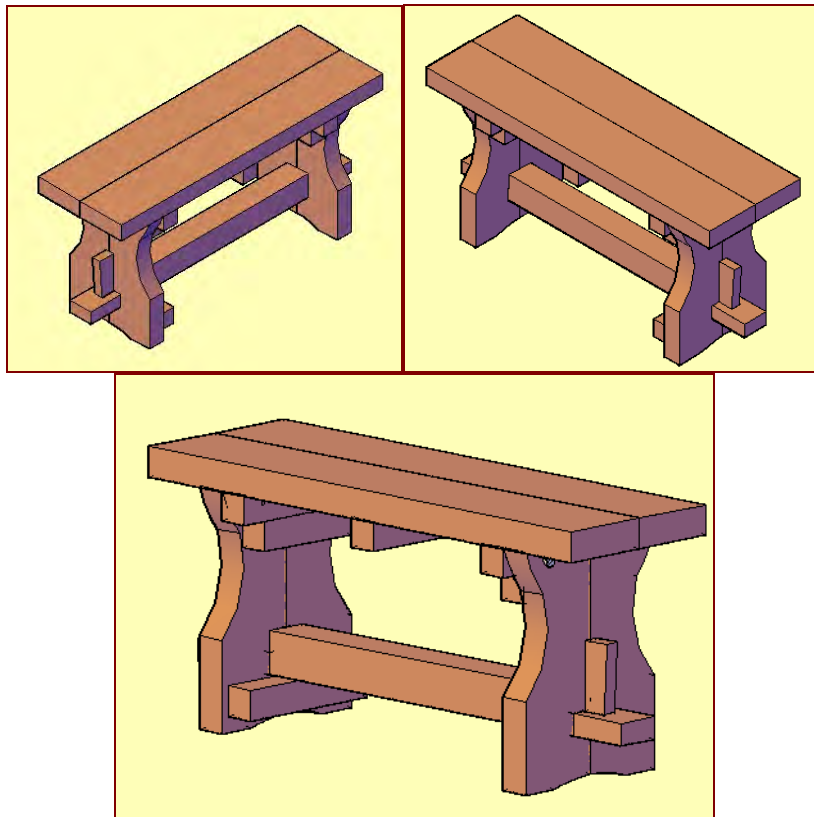

Old-Growth Again
 Restoring Logged Forests
 One Tree At A Time



3FT TRESTLE BENCH

Number of boxes: 2

Box 1 of 2:

Quantity	Description	Drawing
4	Carriage Bolts 3 1/2" x 5/16", Washers and Nuts	
2	Leg Assemblies left (C) & right (D)	

Box 2 of 2:

Quantity	Description	Drawing
2	Trestle beam (B)	
2	Leg Supports (E, F)	
1	Seat (A)	

ASSEMBLY INSTRUCTIONS

CONTENT OF THE BOXES

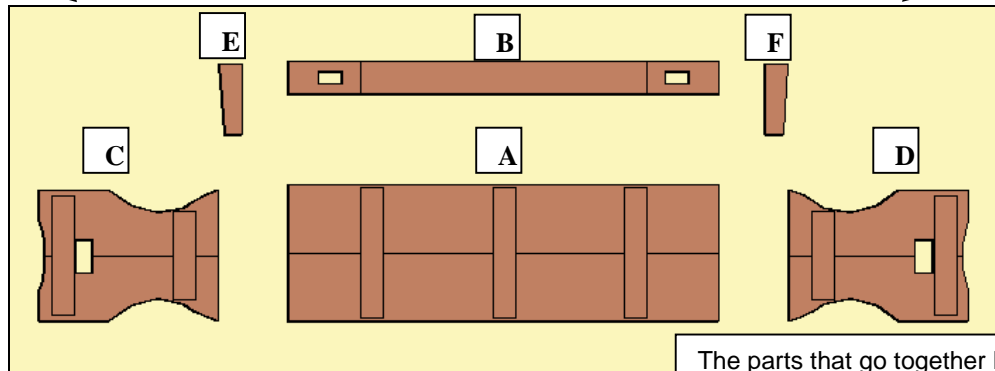

The parts that go together have the same numbers written next to the predrilled holes they attach to. Align the parts with the numbers as shown for ease of reference.

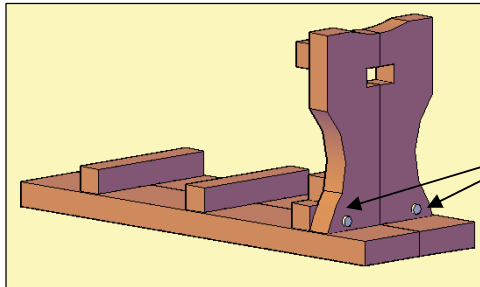

STEP 1:

Attach part D (leg assembly right) to parts A (seat), with 2 bolts (3 1/2" x 5/16"), washers & nuts (into two holes marked "1"). Tap the bolt all the way into the wood to set it. Then add a washer and nut and lightly tighten.

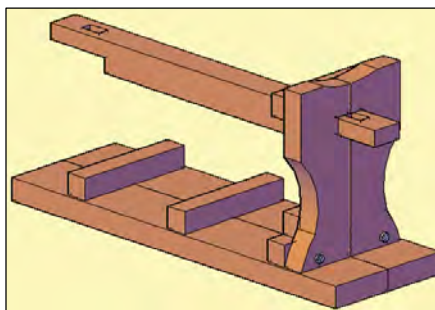

STEP 2:

Insert part B (Trestle beam) in part D (leg assembly right).

STEP 3:

Insert part B (Trestle beam) in part C (leg assembly left).

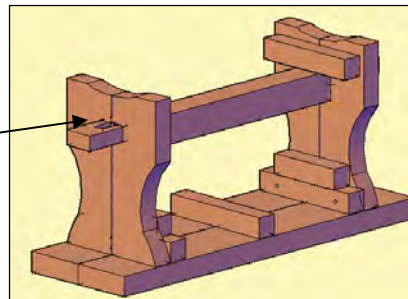

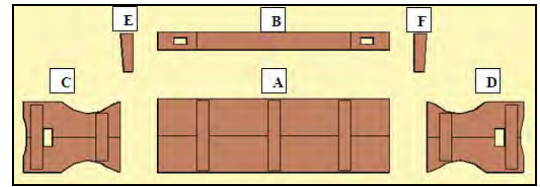

STEP 4:
 Attach part C (leg assembly right) to part A (seat), with 2 bolts (3 1/2" x 5/16"), washers & nuts (into two holes marked "4"). Tap the bolt all the way into the wood to set it. Then add a washer and nut and lightly tighten.

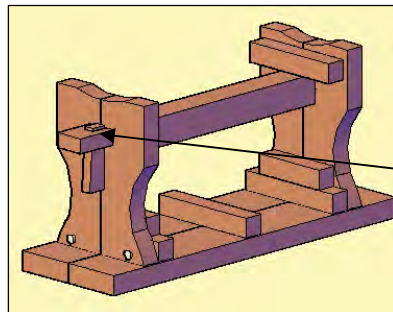
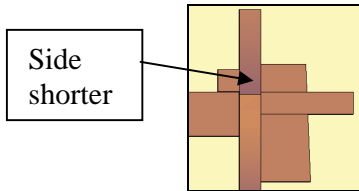
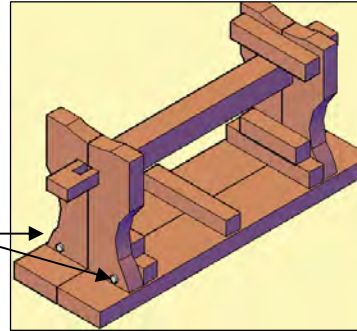

STEP 5:
 Insert part E (leg support) in part B (Trestle beam).

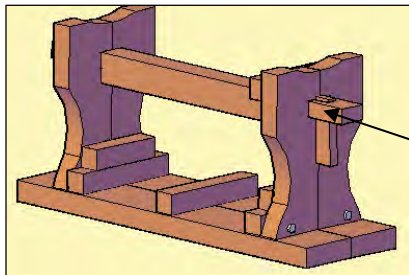

STEP 6:
 Insert part E (leg support) in part B (Trestle beam).