



Old-Growth Again  
Restoring Logged Forests  
One Tree At A Time



## ASSEMBLY INSTRUCTIONS FOR: 6FT TRESTLE TABLE



Old-Growth Again  
Restoring Logged Forests  
One Tree At A Time



## 6ft TRESTLE TABLE

**Number of boxes: 3**

Box 1 of 3:

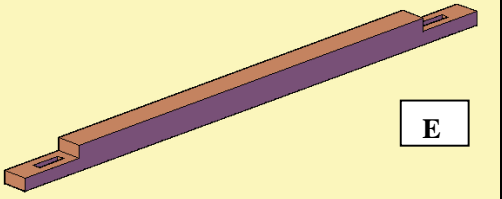
Quantity	Description	Drawing
12	Carriage Bolts 3 1/2" x 5/16", Washers and Nuts	
1	Trestle beam (E)	

Box 2 of 3:

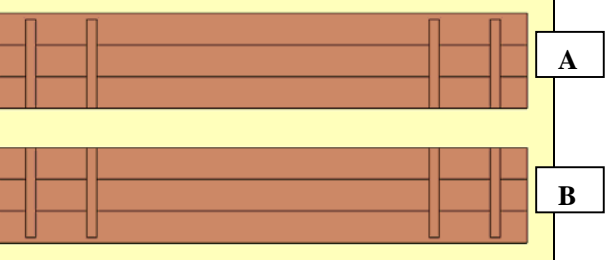
Quantity	Description	Drawing
2	Tabletop halves (A, B)	

Box 3 of 3:

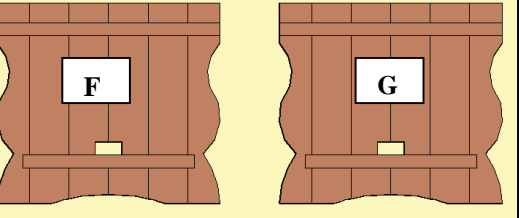
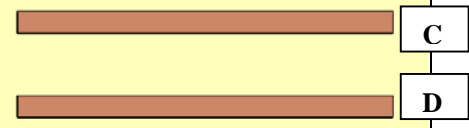
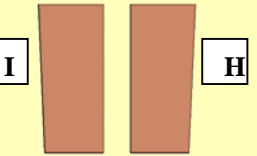
Quantity	Description	Drawing
2	Leg assemblies left & right (F, G)	
2	Tabletop supports (C, D)	
2	Leg supports (H, I)	

# ASSEMBLY INSTRUCTIONS

## CONTENT OF THE BOXES

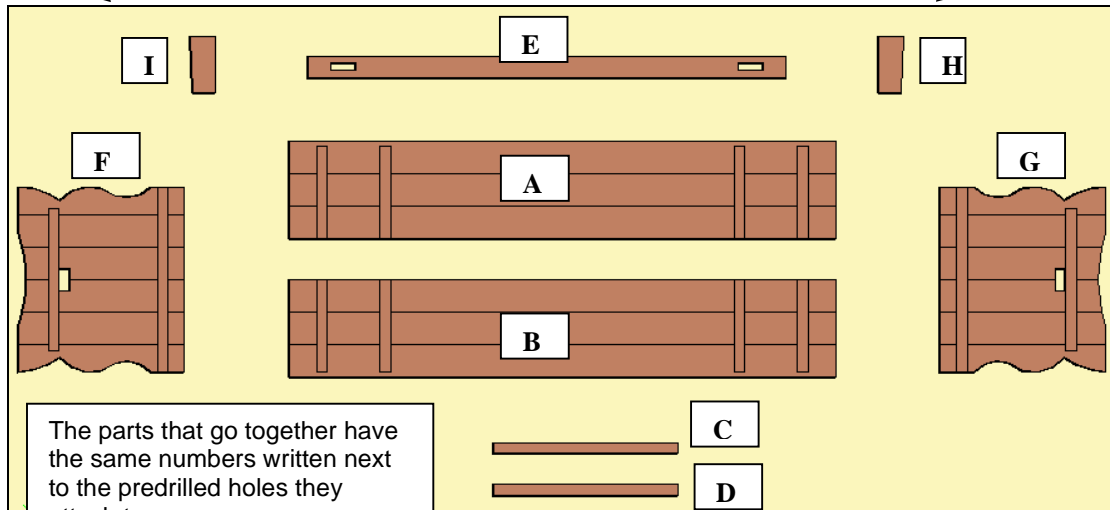

The parts that go together have the same numbers written next to the predrilled holes they attach to. Align the parts with the numbers as shown for ease of reference.

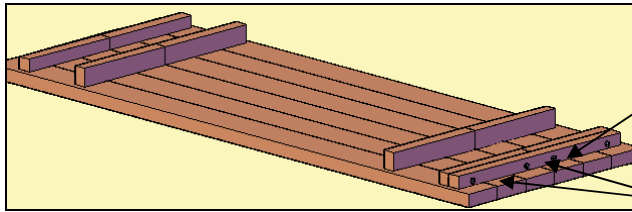

### **STEP 1:**

Attach part C (tabletop support) to parts A & B (tabletop halves), with 4 bolts ( $3\frac{1}{2}$ " x  $\frac{5}{16}$ " ), washers & nuts (into four holes marked "1"). Tap the bolt all the way into the wood to set it. Then add a washer and nut and lightly tighten.

### **STEP 2:**

Attach part D (tabletop support) to parts A & B (tabletop halves), with 4 bolts ( $3\frac{1}{2}$ " x  $\frac{5}{16}$ " ), washers & nuts (into four holes marked "2"). Tap the bolt all the way into the wood to set it. Then add a washer and nut and lightly tighten.

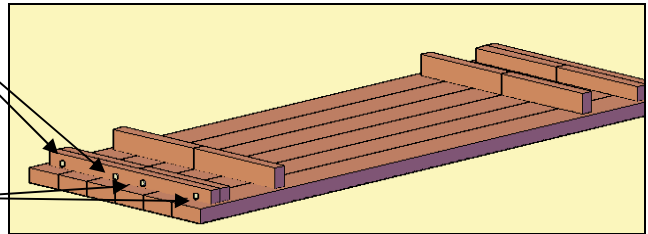

### **STEP 3:**

Attach part F (leg assembly left) to parts A & B (tabletop halves), with two bolts ( $3\frac{1}{2}$ " x  $\frac{5}{16}$ " ), washers & nuts (into four holes marked "3"). Tap the bolt all the way into the wood to set it. Then add a washer and nut and lightly tighten.

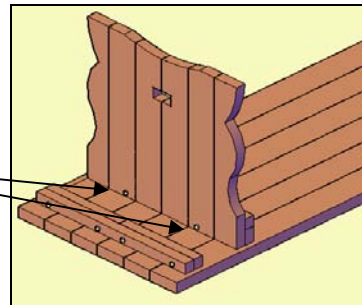

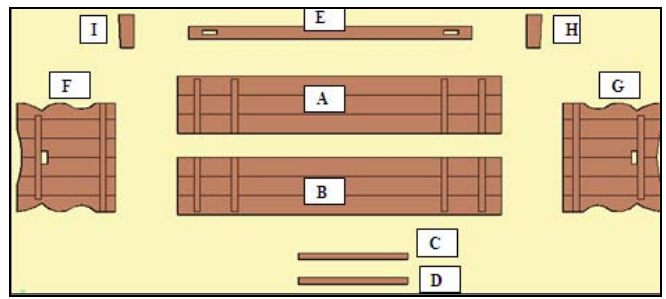

**STEP 4:**  
 Insert part E (Trestle beam) in part F (leg assembly left).

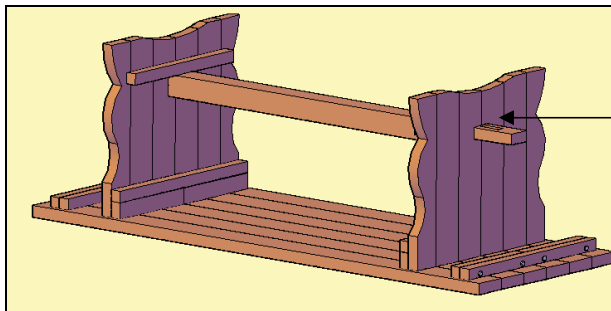
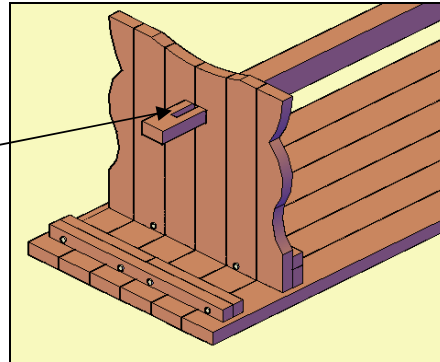

**STEP 5:**  
 Insert part E (Trestle beam) in part G (leg assembly right)

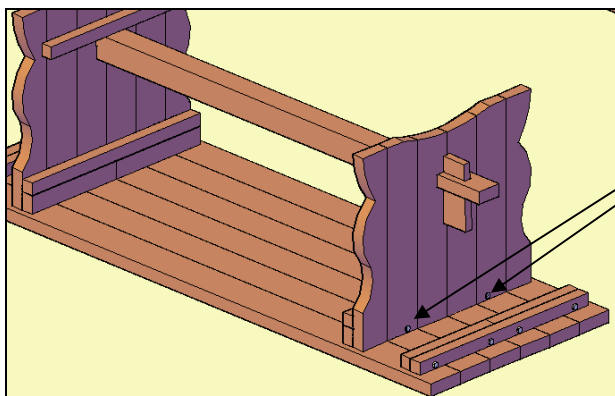

**STEP 6:**  
 Attach part G (leg assembly right) to parts A & B (tabletop halves), with two bolts (3 1/2" x 5/16"), washers & nuts (into four holes marked "6"). Tap the bolt all the way into the wood to set it. Then add a washer and nut and lightly tighten

Side shorter

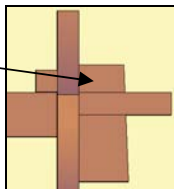

**STEP 7:**  
 Insert part H (leg support) in part E (Trestle beam)

**STEP 8:**  
 Insert part I (leg support) in part E (trestle beam).

