

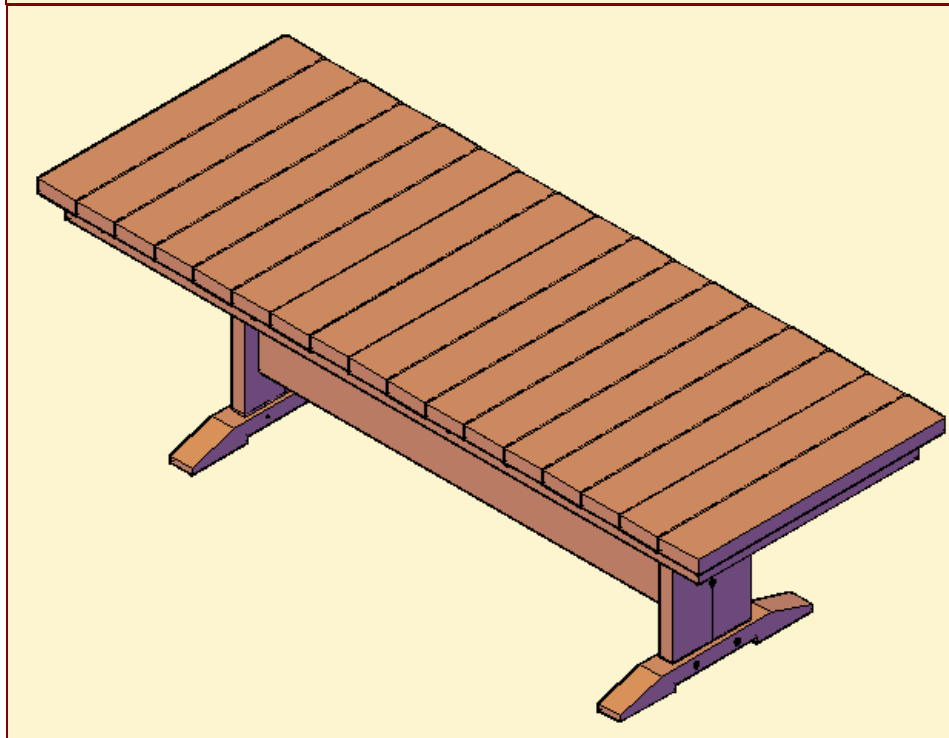

Old-Growth Again
Restoring Logged Forests
One Tree At A Time

Young Growth – Mature Growth – Old Growth

ASSEMBLY INSTRUCTIONS FOR BAJA TRESTLE TABLES (all sizes)

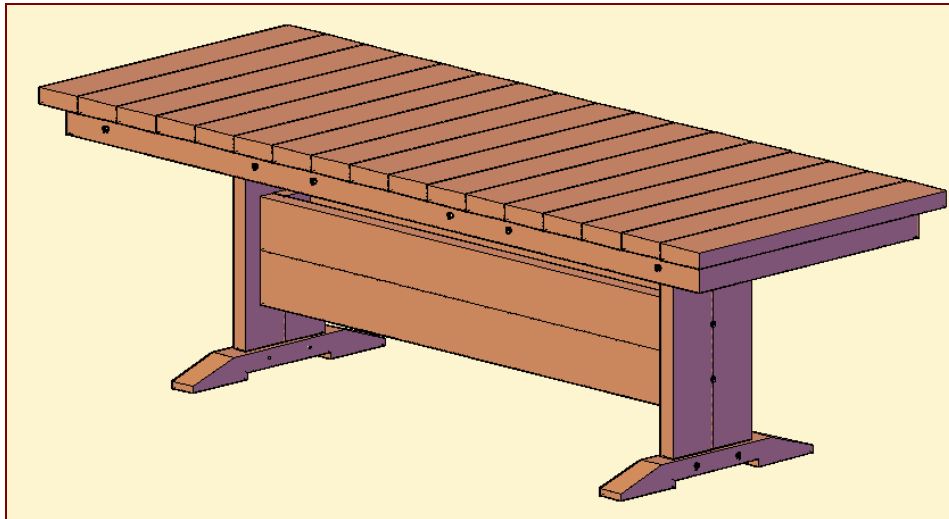



BAJA TRESTLE TABLES (All sizes)

Number of boxes: 4

Box 1 of 4:

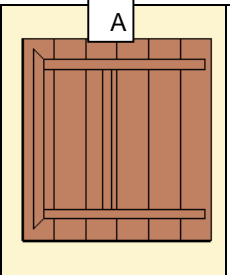
Quantity	Description	Drawing
20	Carriage bolts $\frac{5}{16}$ " x 4", Washers and Nuts	
1	Tabletop (A)	

Box 2 of 4:

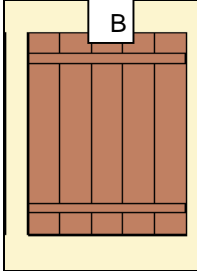
Quantity	Description	Drawing
1	Tabletop (B)	

Box 3 of 4:

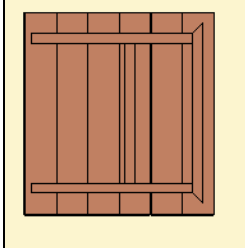
Quantity	Description	Drawing
1	Tabletop (C)	

Box 4 of 4:

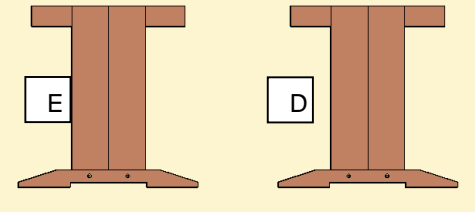
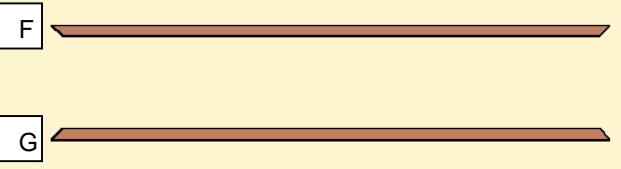
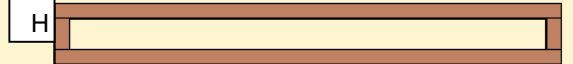
Quantity	Description	Drawing
2	Leg assemblies right (D) and left (E)	
2	Top Supports (F, G)	
1	Leg Supports (H)	

ASSEMBLY INSTRUCTIONS

CONTENT OF THE BOXES

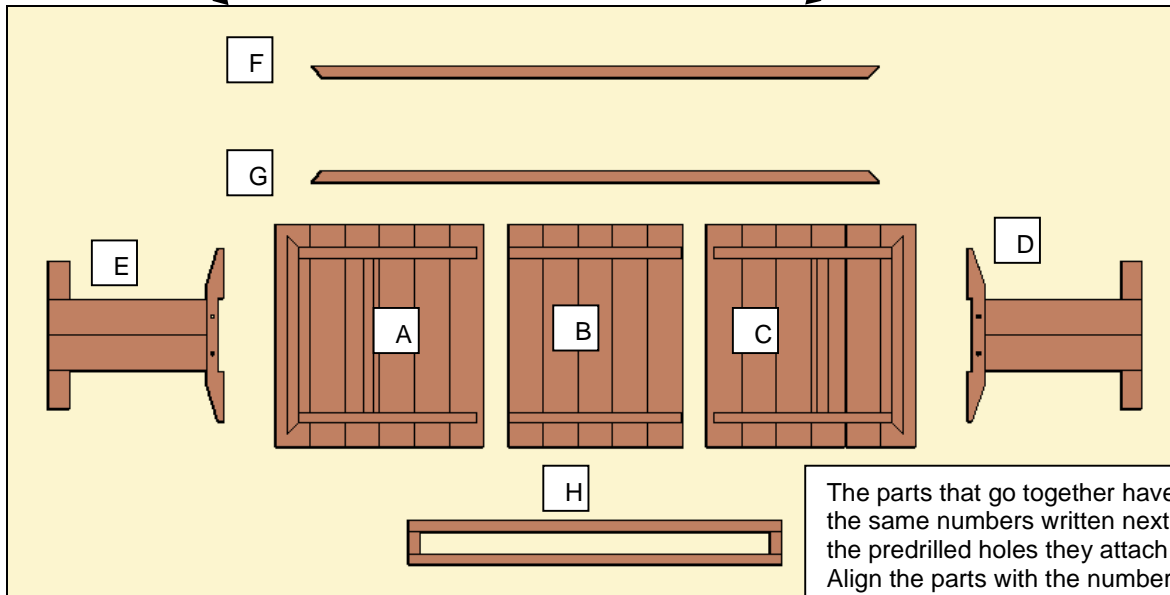

The parts that go together have the same numbers written next to the predrilled holes they attach to. Align the parts with the numbers as shown for ease of reference.

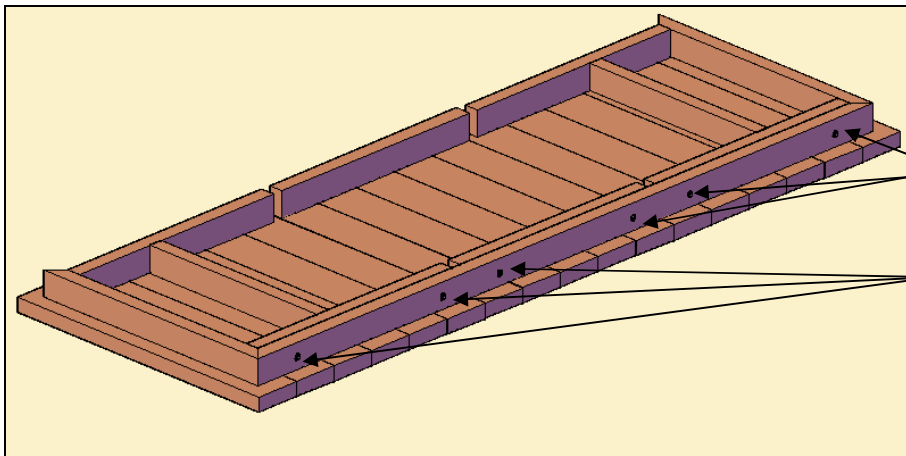

STEP 1:

Attach part F (tabletop support) to part A, B & C (Tabletop), with six bolts (4" x 5/16"), washers & nuts (into six holes marked "3"). Tap the bolt all the way into the wood to set it. Then add a washer and nut and lightly tighten.

STEP 2:

Attach part G (tabletop support) to part A, B & C (Tabletop), with six bolts (4" x 5/16"), washers & nuts (into six holes marked "4"). Tap the bolt all the way into the wood to set it. Then add a washer and nut and lightly tighten.

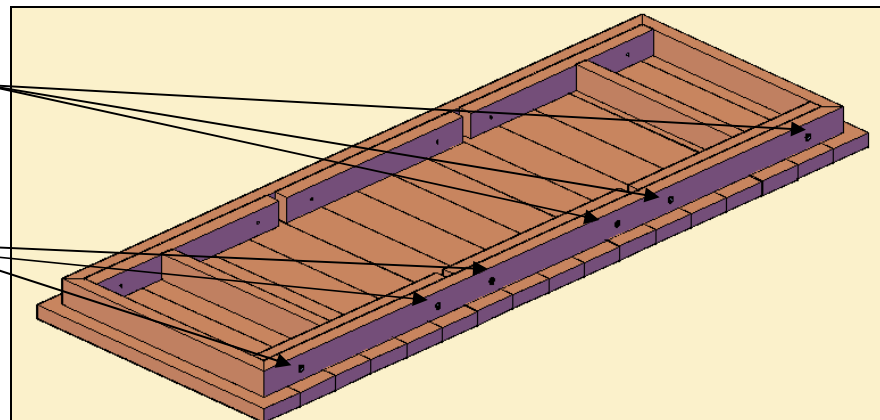

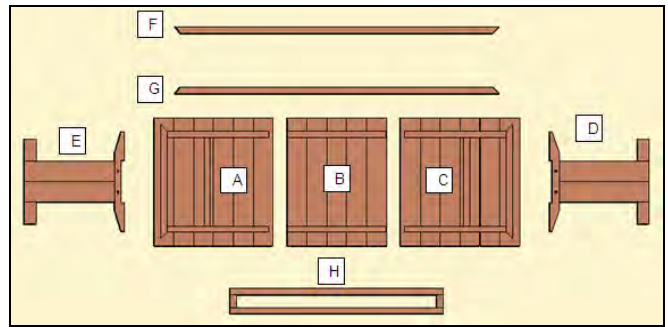

STEP 3:

Attach part E (leg assembly left) to part H (leg support), with two bolts (4" x 5/16"), washers & nuts (into two holes marked "5"). Tap the bolt all the way into the wood to set it. Then add a washer and nut and lightly tighten.

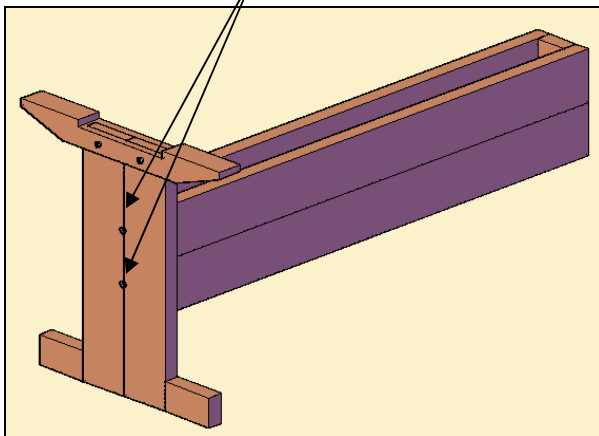

STEP 4:

Attach part D (leg assembly right) to part H (leg support), with two bolts (4" x 5/16"), washers & nuts (into two holes marked "6"). Tap the bolt all the way into the wood to set it. Then add a washer and nut and lightly tighten.

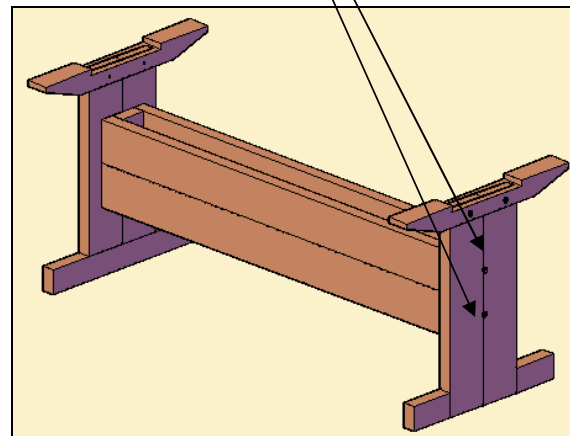

STEP 5:

Attach part E (leg assembly left) to part A (tabletop), with two bolts (4" x 5/16"), washers & nuts (into two holes marked "7"). Tap the bolt all the way into the wood to set it. Then add a washer and nut and lightly tighten.

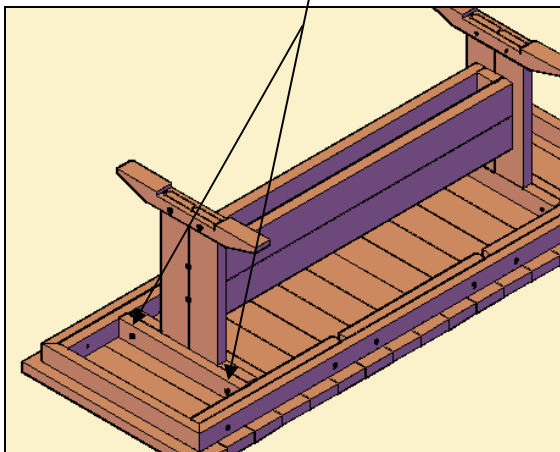

STEP 6:

Attach part D (leg assembly right) to part C (tabletop), with two bolts (4" x 5/16"), washers & nuts (into two holes marked "8"). Tap the bolt all the way into the wood to set it. Then add a washer and nut and lightly tighten.

