



# FOREVER REDWOOD

*From the Forest, For the Forest since 1995*

---









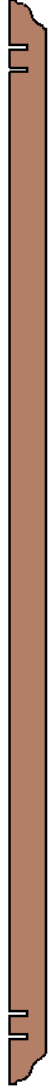

866.332.2403 (TOLL FREE); 7am – 7pm Pacific Time, Monday-Saturday

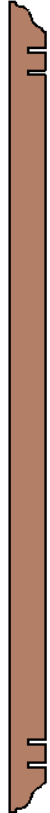
## ASSEMBLY INSTRUCTIONS FOR **CHERRY HILL OUTDOOR PERGOLA**

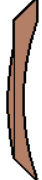
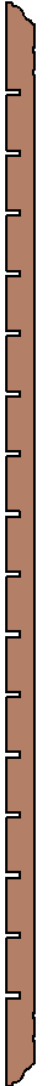







CONTENT OF BOXES

Qty.	Description	Drawing	No.	
	Posts		1	
	Long Single Supports		2	
	Long Supports with In-Between Blocking		3	
	Short Single Supports		4	
	Short Supports with In-Between Blocking		5	
Will Vary	Knee Braces		6	
	Long Rafters		7	
	Short Rafters		8	
	Boots <b>If ordered</b>		9	
	Standard, Gale Wind or Hurricane Anchor Bases <b>If ordered</b>		10	
				Gale Wind
				Hurricane

Note: Part numbers in the Content of Boxes Table are for reference only. These do not match to the numbers marked on the parts sent.

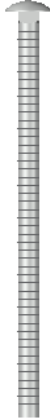
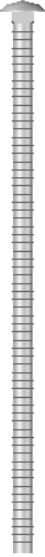
## HARDWARE LIST

Description	Drawing	No.
<p>1/2" x 4" Anchor Bolts (To attach the anchor bases to the ground).</p>		A
<p>3/8" x 3" Lag Bolts (To attach the anchor bases to the posts).</p>		B
<p>3/8" x 7 1/2" Bolts (To attach the supports to the posts. / To attach the supports together. / To attach the knee braces the supports).</p>		C
<p>3/8" x 10" Bolts (To attach the knee braces to the posts).</p>		D
<p>3" Deck Screws (To attach the rafters to the supports. / To attach the rafters together. / To attach the bolts to the posts).</p>		E

DESCRIPTION	No
Posts	1
Long Single Supports	2
Long Supports with In-Between Blocking	3
Short Single Supports	4
Short Supports with In-Between Blocking	5
Knee Braces	6
Long Rafters	7
Short Rafters	8
Boots	9
Anchor Bases	10

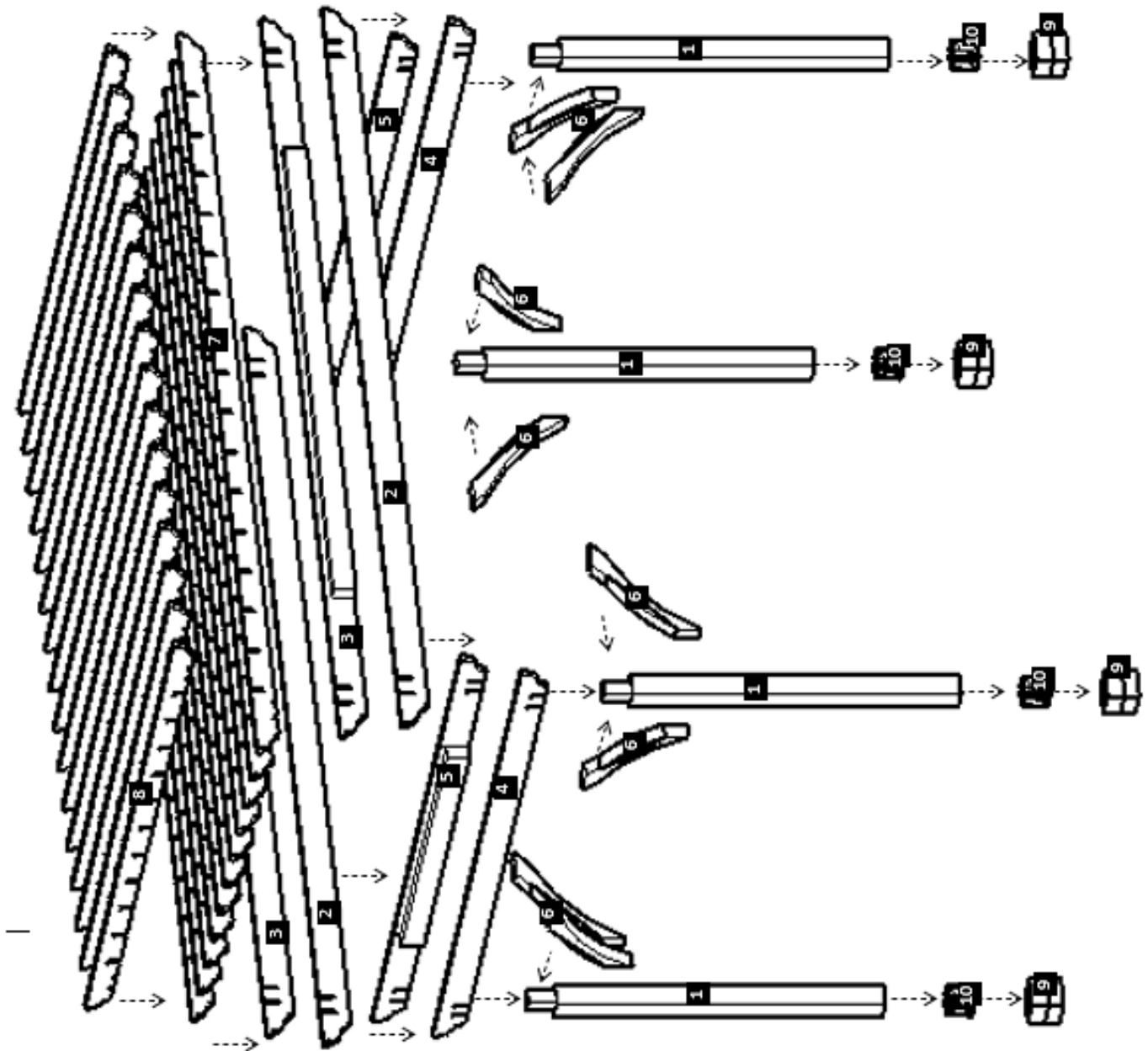

*Note: Part numbers in the Drawing are for reference only. These do not match to the numbers marked on the parts sent.*

**NOTE:** In order to know where the post needs to be placed, check the numbers on them. If the post is not marked, then place the single Supports on the ground to locate the markings for each post position and clearly set your bearings. (“Don’t attach yet, only place them on the ground to begin with”).

**Step 1:** Install the anchor bases (100) to the ground with  $\frac{1}{2}'' \times 4''$  Anchor bolts (A). Please see the “How to anchor your pergola document” for all details. Set your post (1) in the saddle of the anchor bases. Drill a  $\phi 7/16''$  hole in the post prior to anchoring to facilitate the ratcheting of the hardware. After that, use a  $\frac{3}{8}'' \times 3''$  lag bolts (B) to attach each post to its respective anchor base.

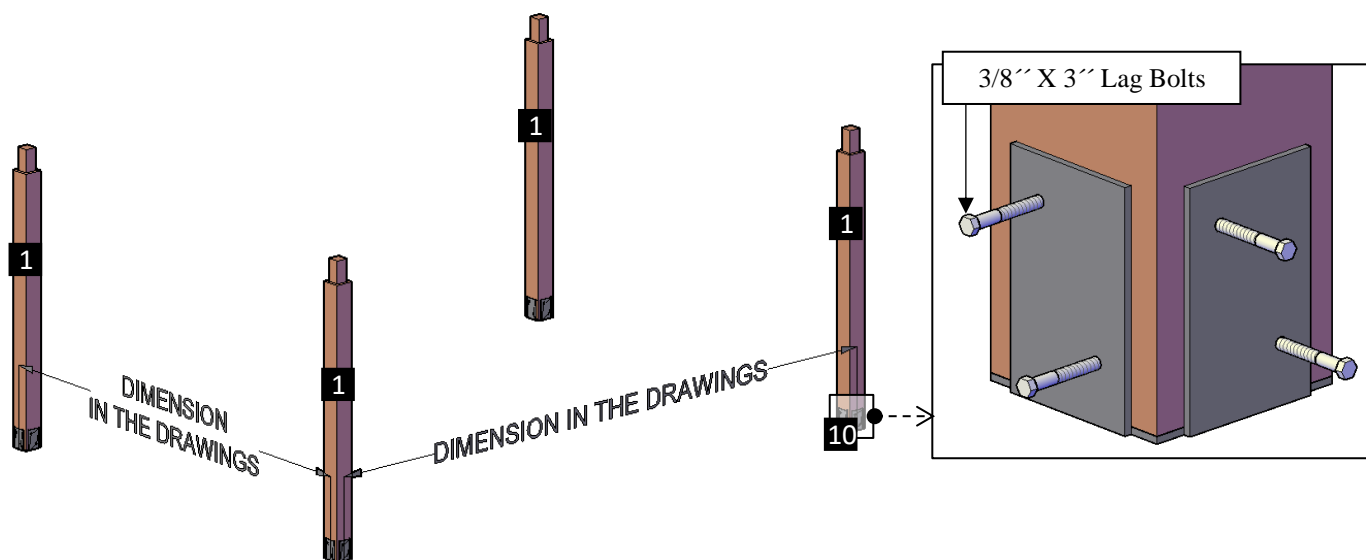

**Step 2:** Attach the long single supports (2) to the posts with  $\frac{3}{8}'' \times 7 \frac{1}{2}''$  bolts (C). Each part has a series of numbers that indicate where to attach the part with the corresponding number.

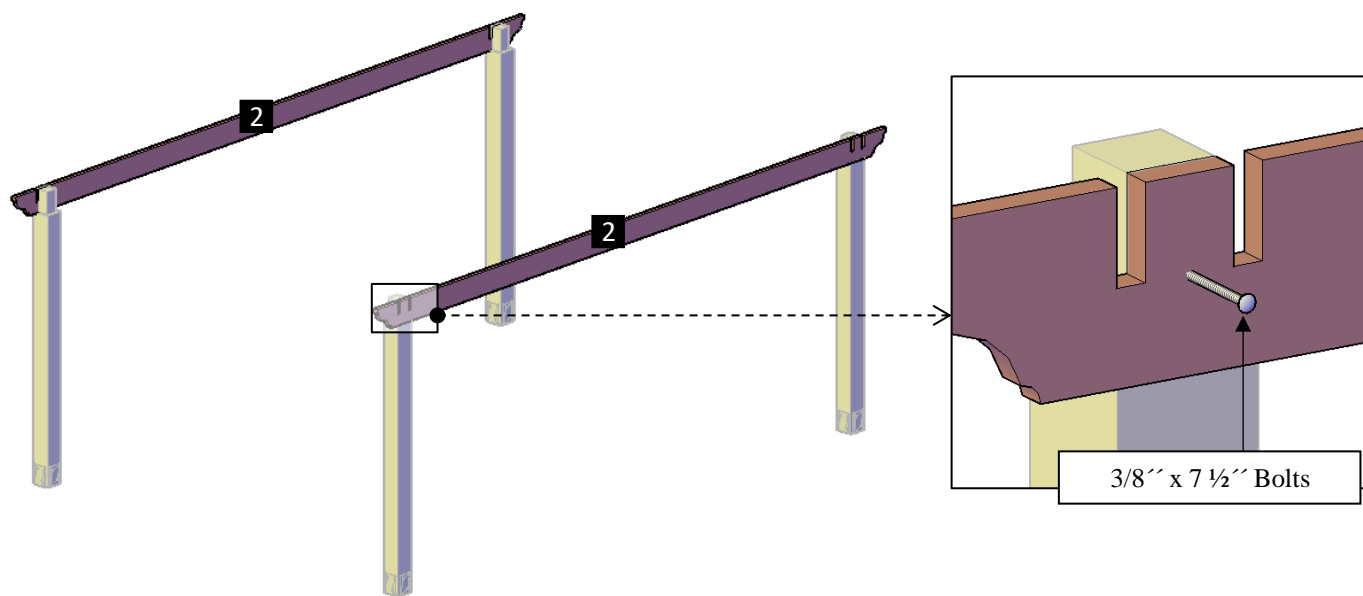

**Step 3:** Put up the long supports with in-between blocking (3), into the post notches as shown and attach to the posts with the single support bolts. Each part has a series of numbers that indicate where to attach the part with the corresponding number.

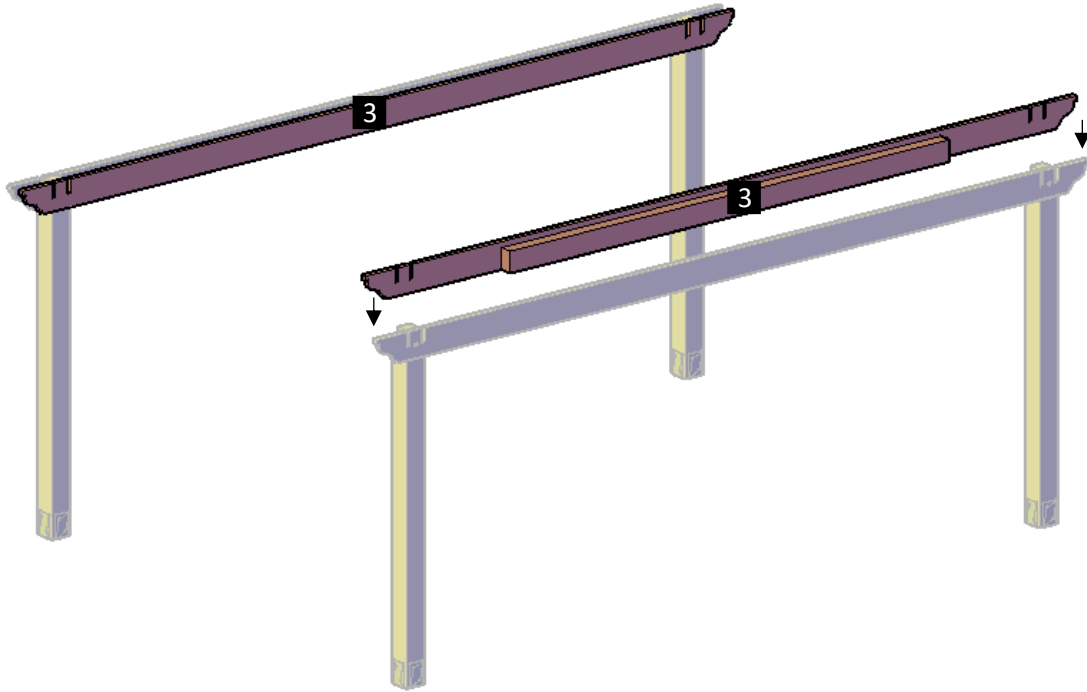

**Step 4:** Attach the long single supports to the long supports with in-between blocking, use 3/8" X 7 1/2" bolts (C).

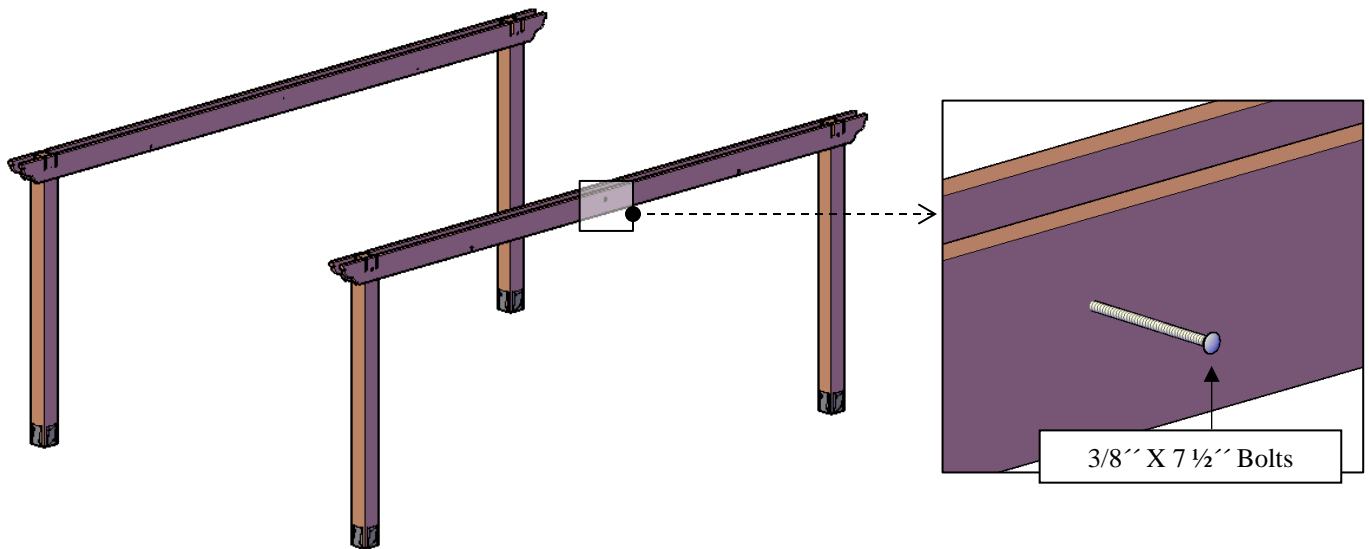

**Step 5:** To attach the short supports (4,5) repeat the steps 2 to 4 above. Make sure that the supports fit correctly. Each part has a series of numbers that indicate where to attach the part with the corresponding number.

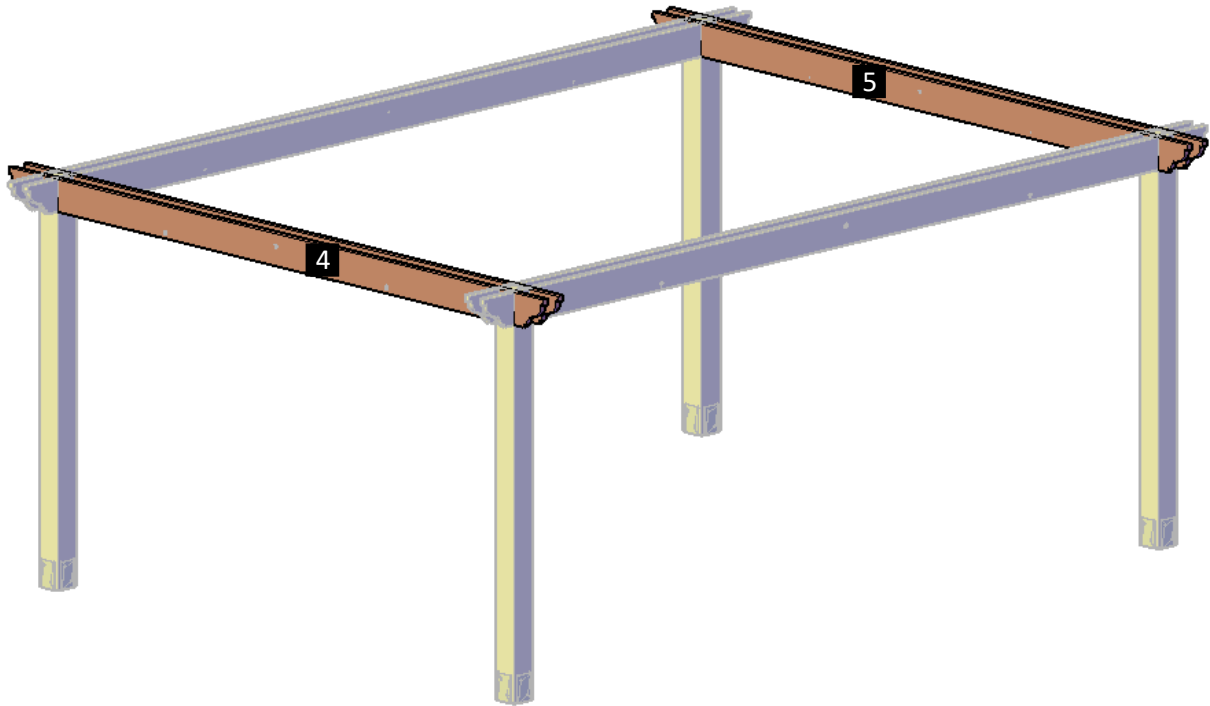

**Step 6:** Attach the knee braces (6) to the supports with 3/8" x 7 1/2" bolts (C), and to the posts with 3/8" x 10" bolts (D). Each part has a series of numbers that indicate where to attach the part with the corresponding number.

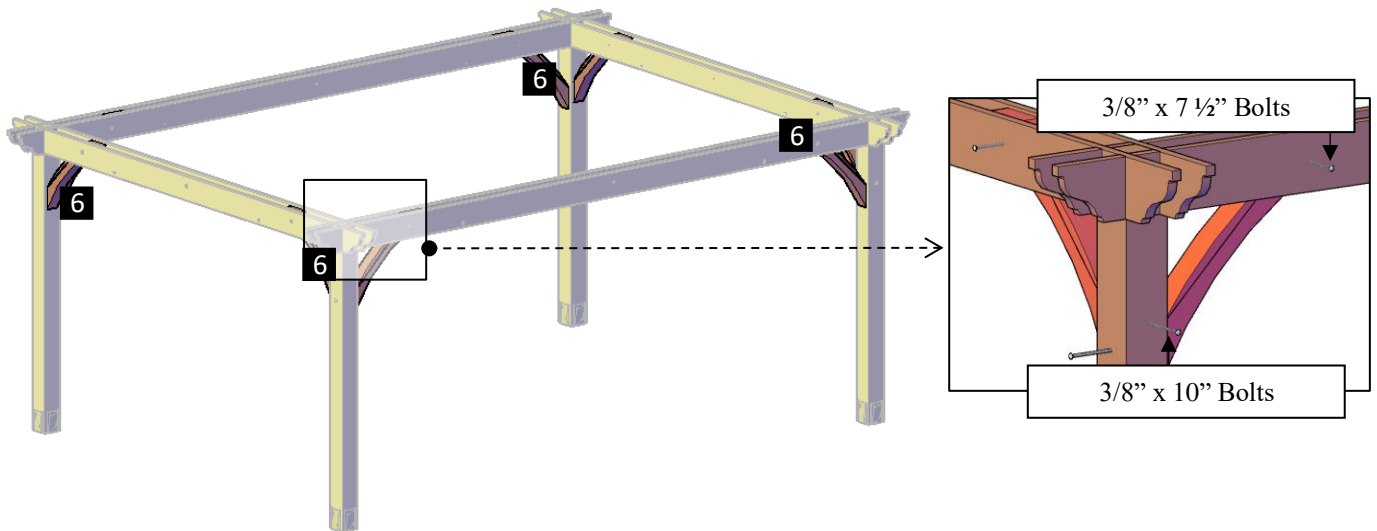

**Step 6:** Use 3'' deck screws (E) to attach the long rafters (7) to the short supports. Each part has a series of numbers that indicate where to attach the part with the corresponding number.

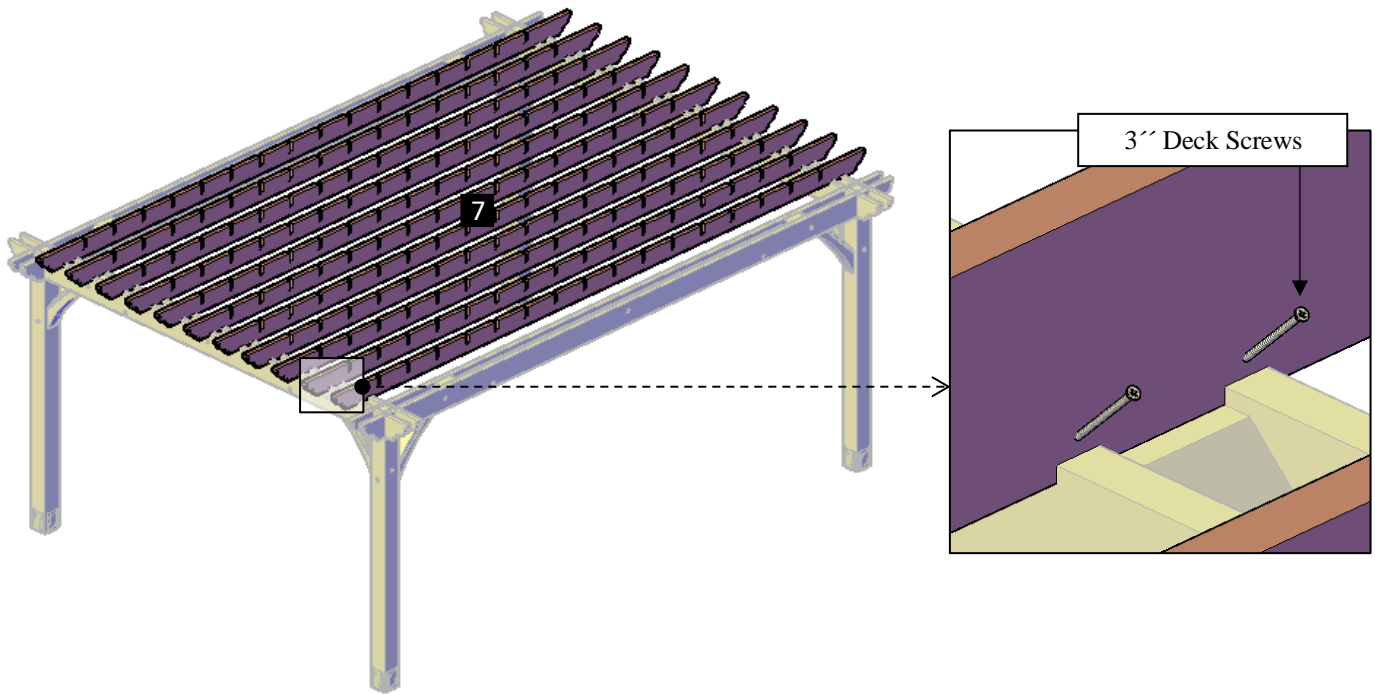

**Step 7:** Attach the short rafters (8) to the long supports and to the long rafters with 3'' deck screws (E). Make sure that the rafters fit correctly. Each part has a series of numbers that indicate where to attach the part with the corresponding number.

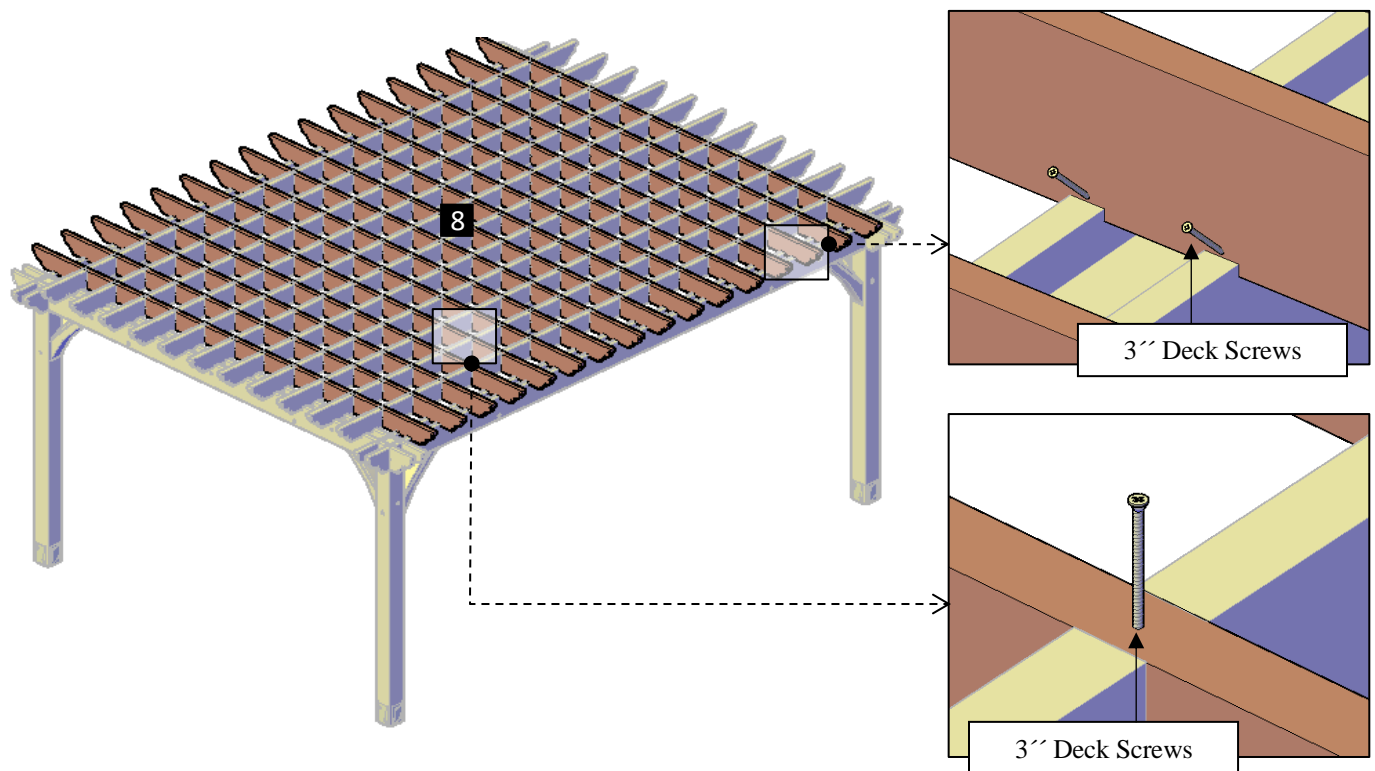



**Step 8:** Finally, use 3'' deck screws (E) to attach the boots (9) to the posts. Each part has a series of numbers that indicate where to attach the part with the corresponding number.

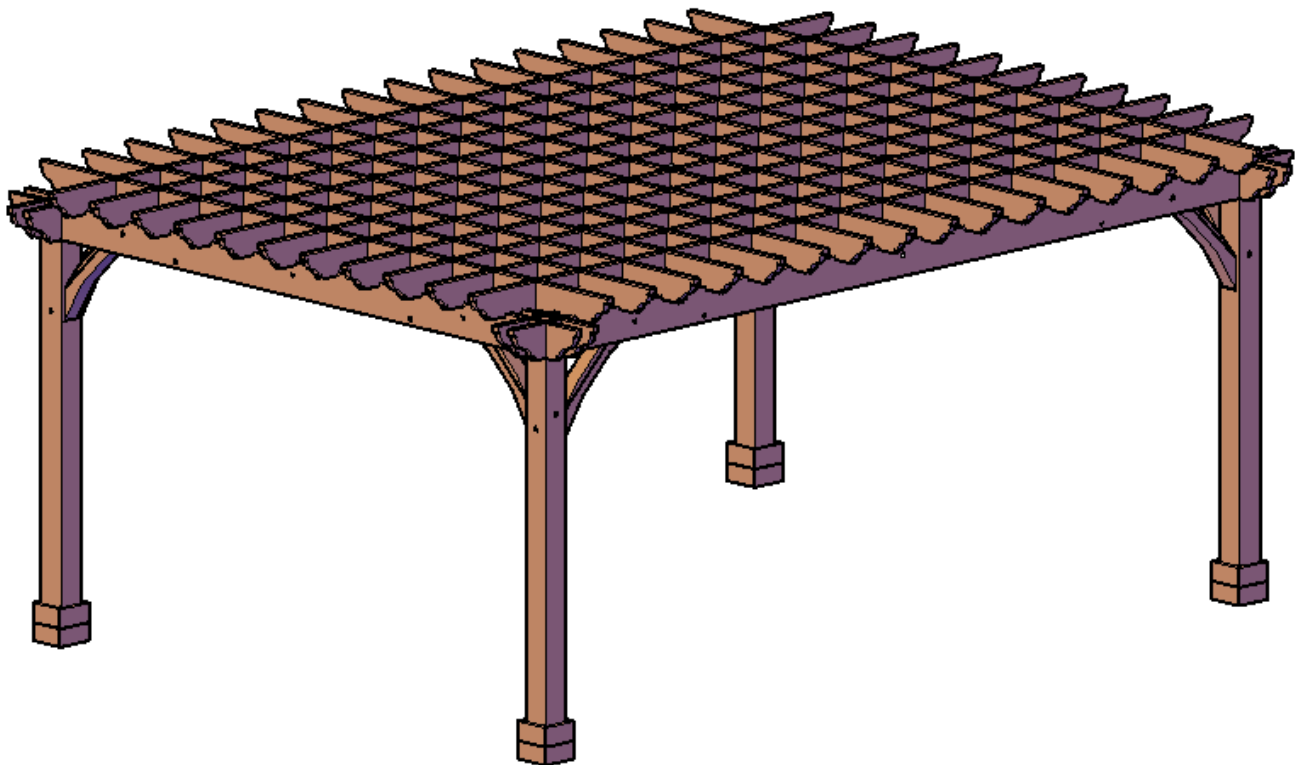
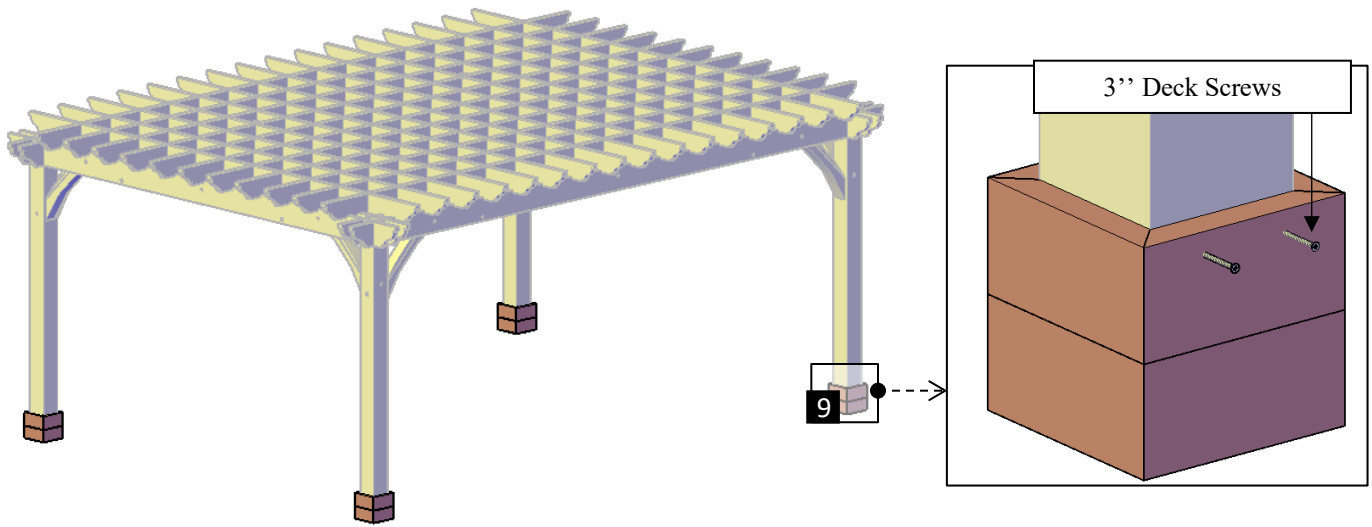

*This completes the Pavilion assembly. Hope you enjoy your set for many decades. If you ever have a problem or a question, don't hesitate to call us (866 332 2403) or email us. We are here to support you.*