



FOREVER REDWOOD

From the Forest, For the Forest since 1995

866.332.2403 (TOLL FREE) (707) 640.29.05 (Option 4) Direct Line for the Design Department; 7am – 7pm Pacific Time, Monday-Saturday

ASSEMBLY INSTRUCTIONS FOR THE ELI'S REDWOOD POTTING BENCH



NOTE: Assembly is best done by two people. To assemble your product, you need a Hammer, a Ratch or a wrench and if required a Drill.

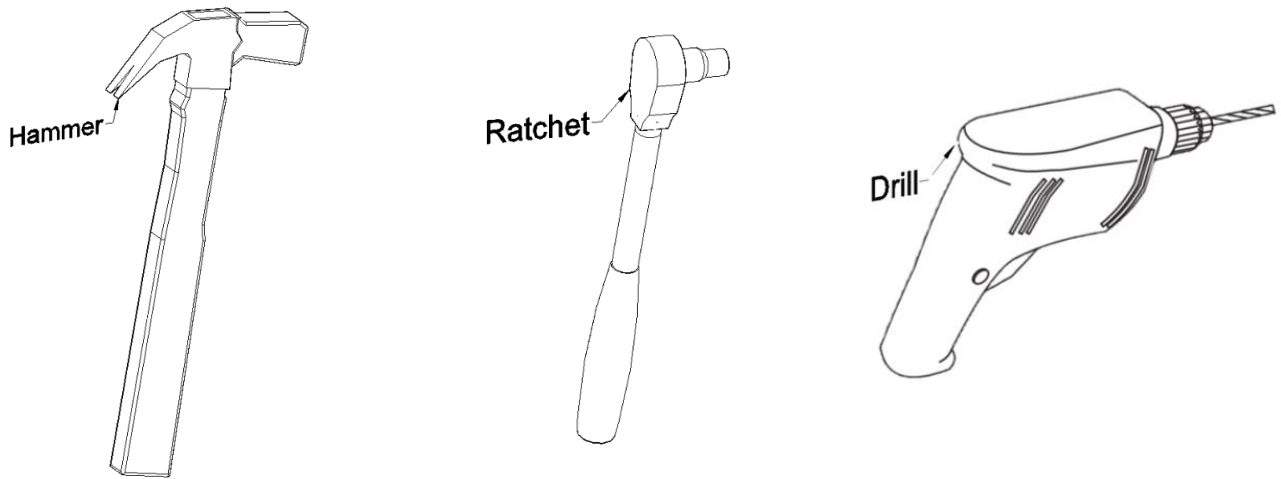

Required Tools (Are not included in your hardware packing).

PROCESS TO INSTALL THE HARDWARE PROVIDED.

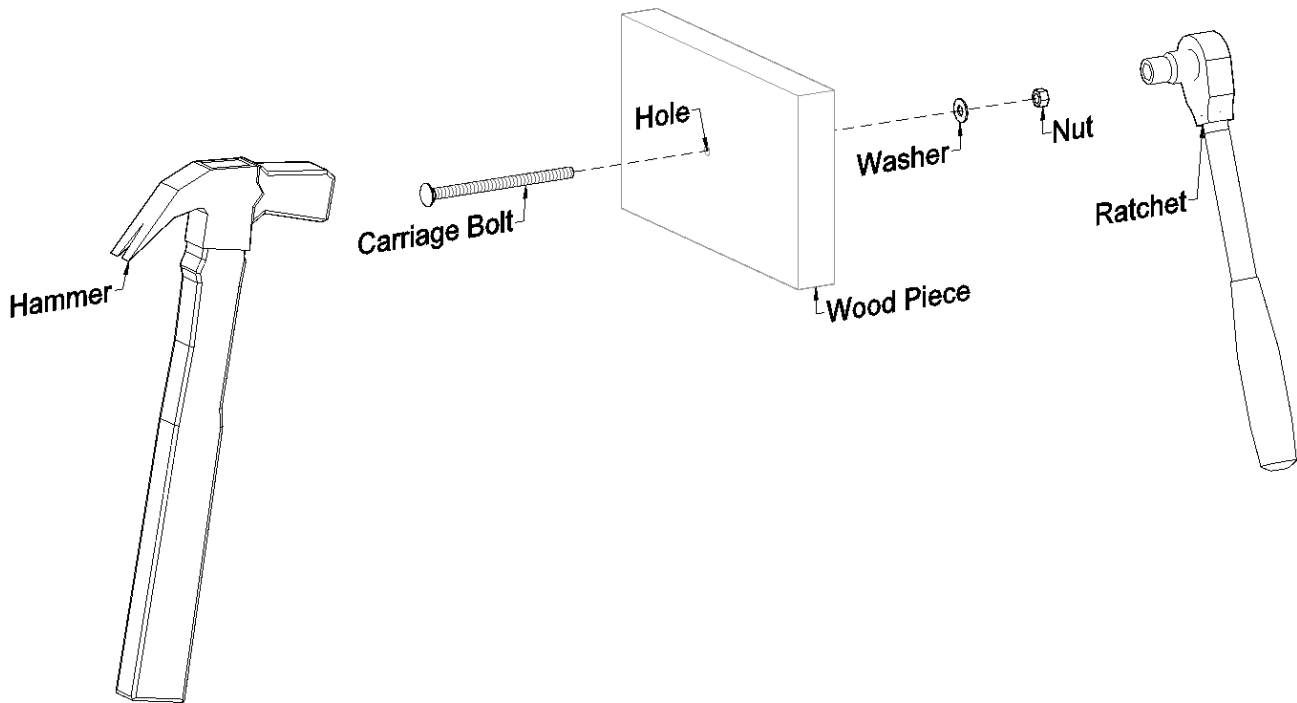

To install the bolts.

Insert the carriage bolts into the holes and lightly tap with a hammer until the square neck fit in the wood piece and the bolt head must flush with the wood piece. Finally, place the washer and the nut and carefully tighten it using a ratchet with the necessary socket or a wrench.

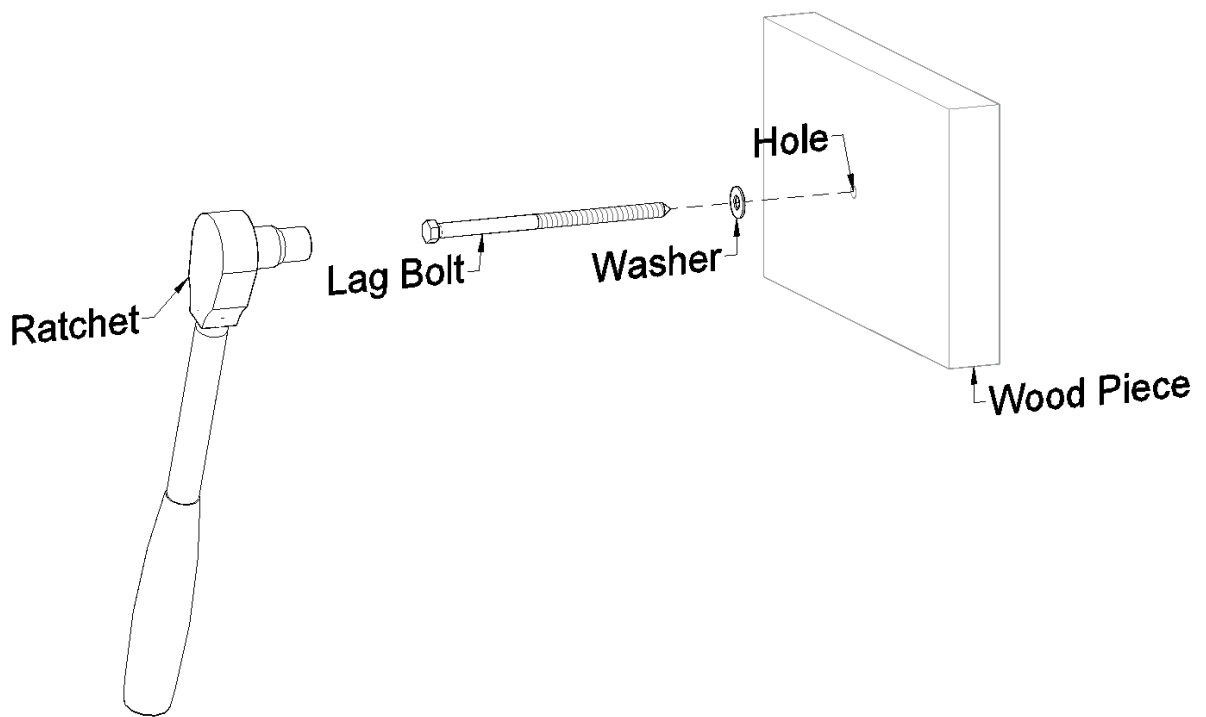

To install the lag bolts.

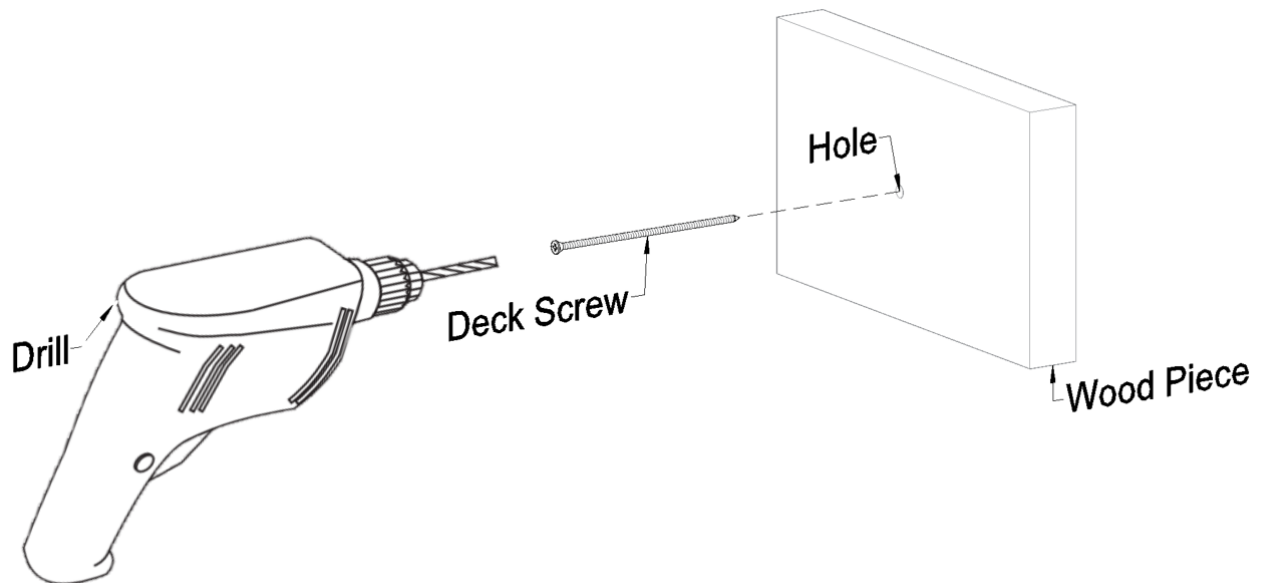

Place the washers in their lag bolts. After that, insert the lag bolts into the holes and carefully tighten it using a **ratchet** with the necessary **socket**.

Use the washers only for the Wood Pieces.



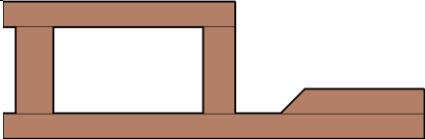
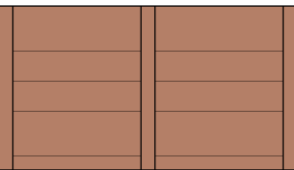
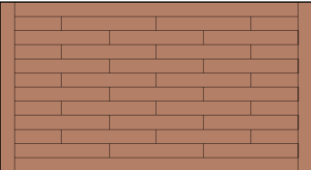

To install the deck screws.

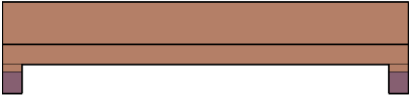
Insert the deck screws into the holes and carefully tighten it using a drill.

CONTENT OF BOXES			
Qty.	Description	Drawing	No.
2	Legs		1
1	Floor		2
1	Parquet shelves		3
2	Drawer		4
2	Shelves		5

Note: Part numbers in the Content of Boxes Table are for reference only. These do not match to the numbers marked on the parts sent.

HARDWARE LIST			
Qty.	Description	Drawing	No.
16	3/8" x 4 1/2" bolts		BL1



DESCRIPTION	No.
Legs	1
Floor	2
Parquet shelves	3
Drawer	4
Shelves	5

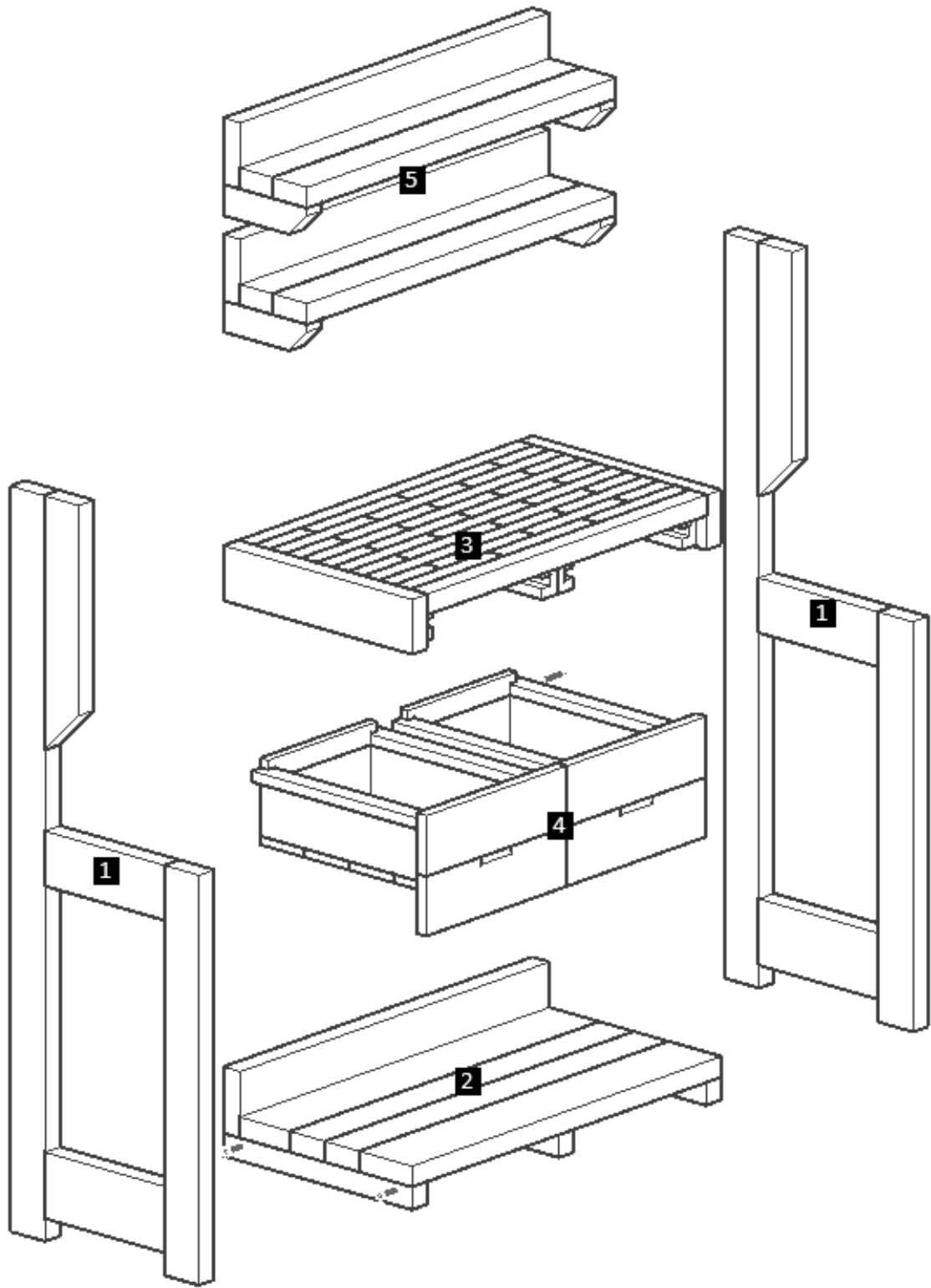

Note: Part numbers in the Drawing are for reference only. These do not match to the numbers marked on the parts sent.

Step 1: Attach the legs (2) to the floor with 3/8" x 4 1/2" bolts (BL1) with washer and nuts. Check the marked numbers on each floor and place

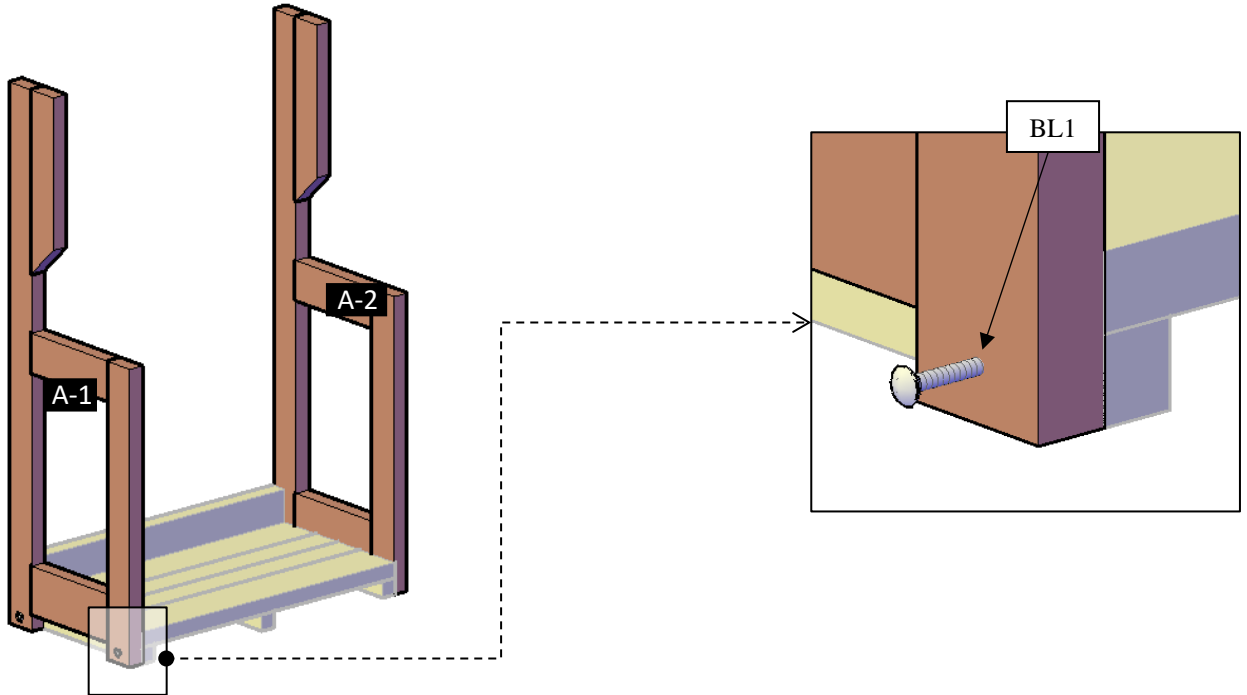

Step 2: Attach the Parquet shelf (2) to the legs (1), use 3/8" x 4 1/2" bolts (BL1) with washer and nuts. Check the marked numbers on each parquet shelf and place as drawings shown.

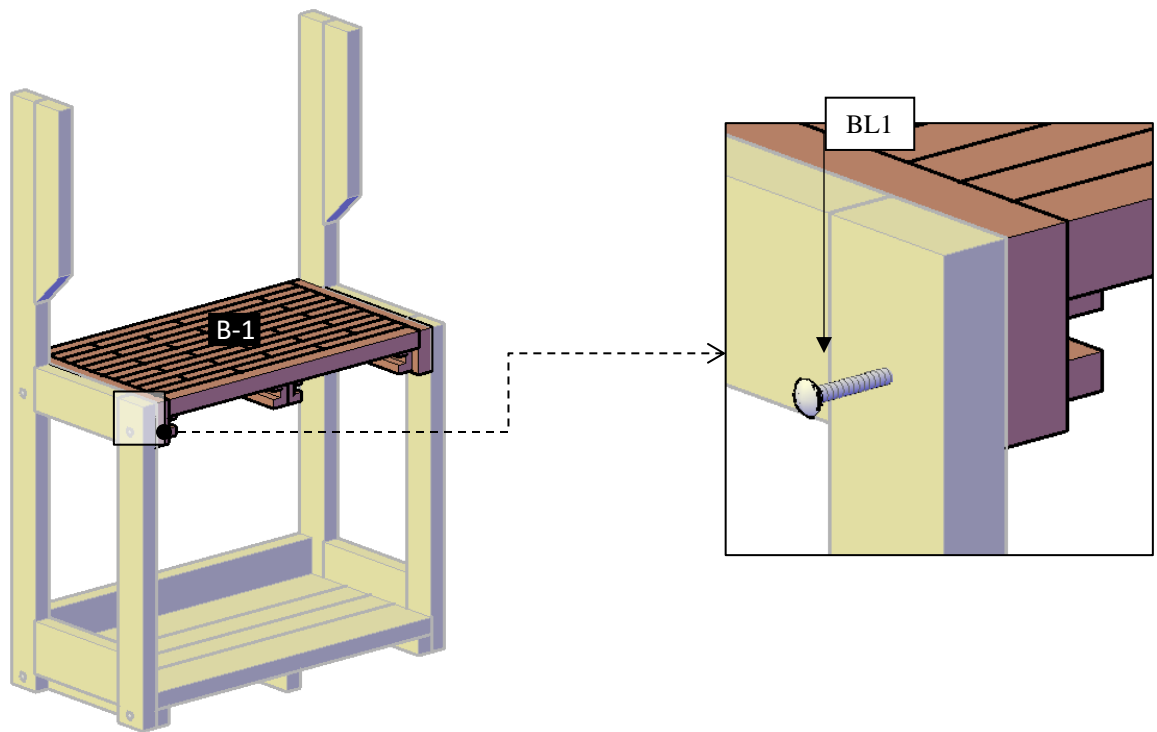

Step 3: Attach the shelves (5) to the legs (1) with 3/8" x 4 1/2" bolts (BL1) with washer and nuts. Check the marked numbers on each shelf and place as drawings shown.

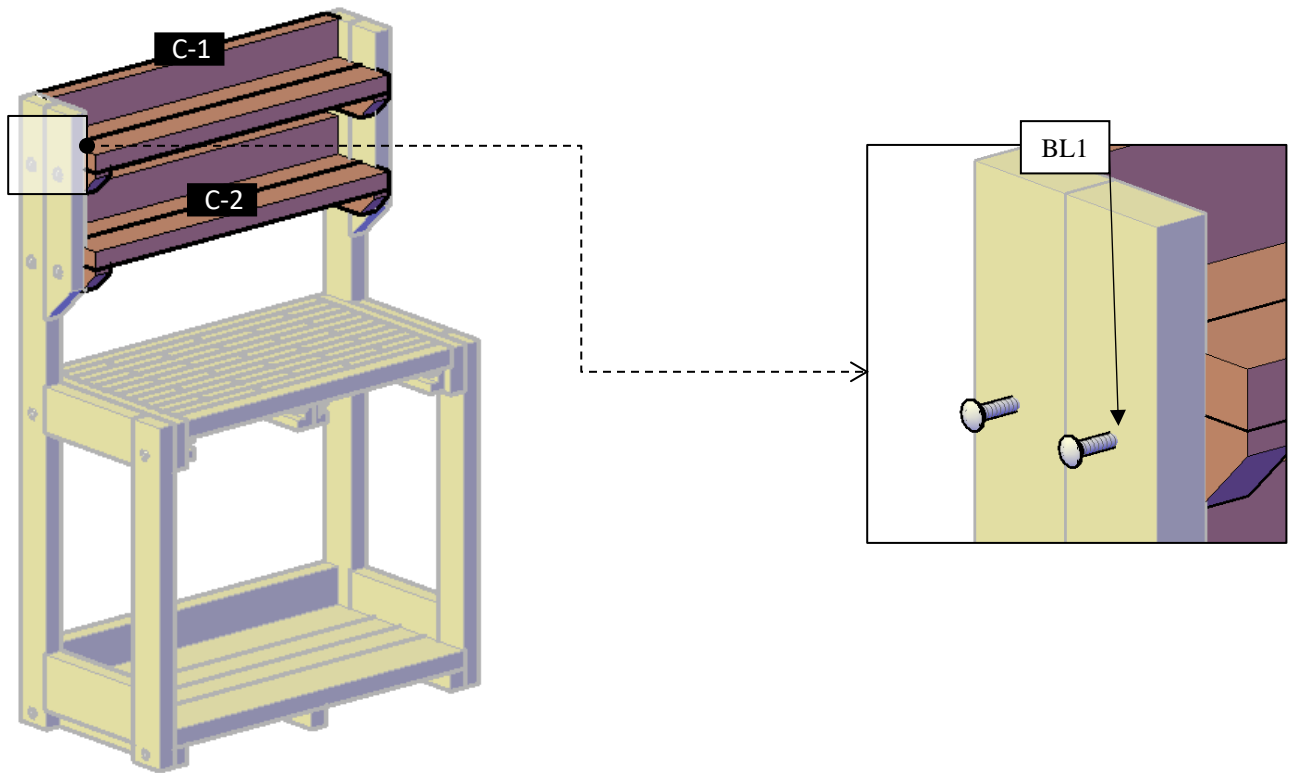

Step 4: Finally, put the drawer (5) in place.

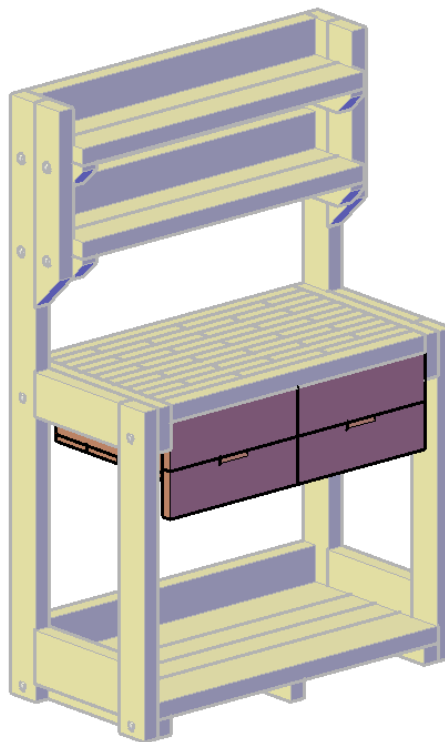



This completes the bench assembly. Hope you enjoy your set for many decades. If you ever have a problem or a question, don't hesitate to call us (866 332 2403) or email us. We are here to support you.