



FOREVER REDWOOD

From the Forest, For the Forest since 1995

866.332.2403 (TOLL FREE) (707) 640.29.05 (Option 4) Direct Line for the Design Department; 7am – 7pm Pacific Time, Monday-Saturday

ASSEMBLY INSTRUCTIONS FOR THE LUNA ARCH BACK WOODEN CHAIR



NOTE: Assembly is best done by two people. To assemble your product, you need a Hammer, a Ratch or a wrench and if required a Drill.

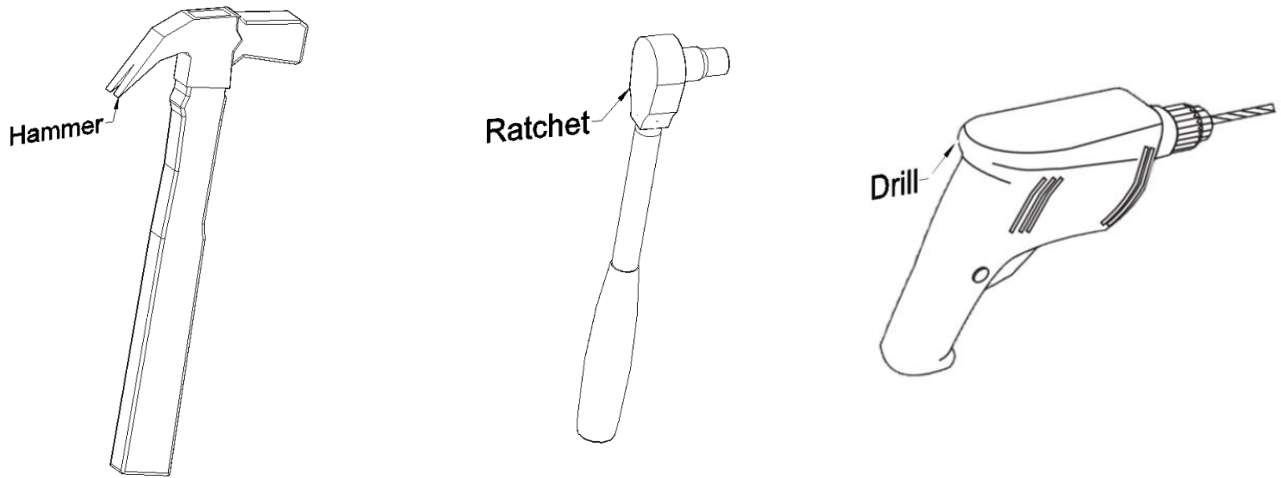

Required Tools (Are not included in your hardware packing).

PROCESS TO INSTALL THE HARDWARE PROVIDED.

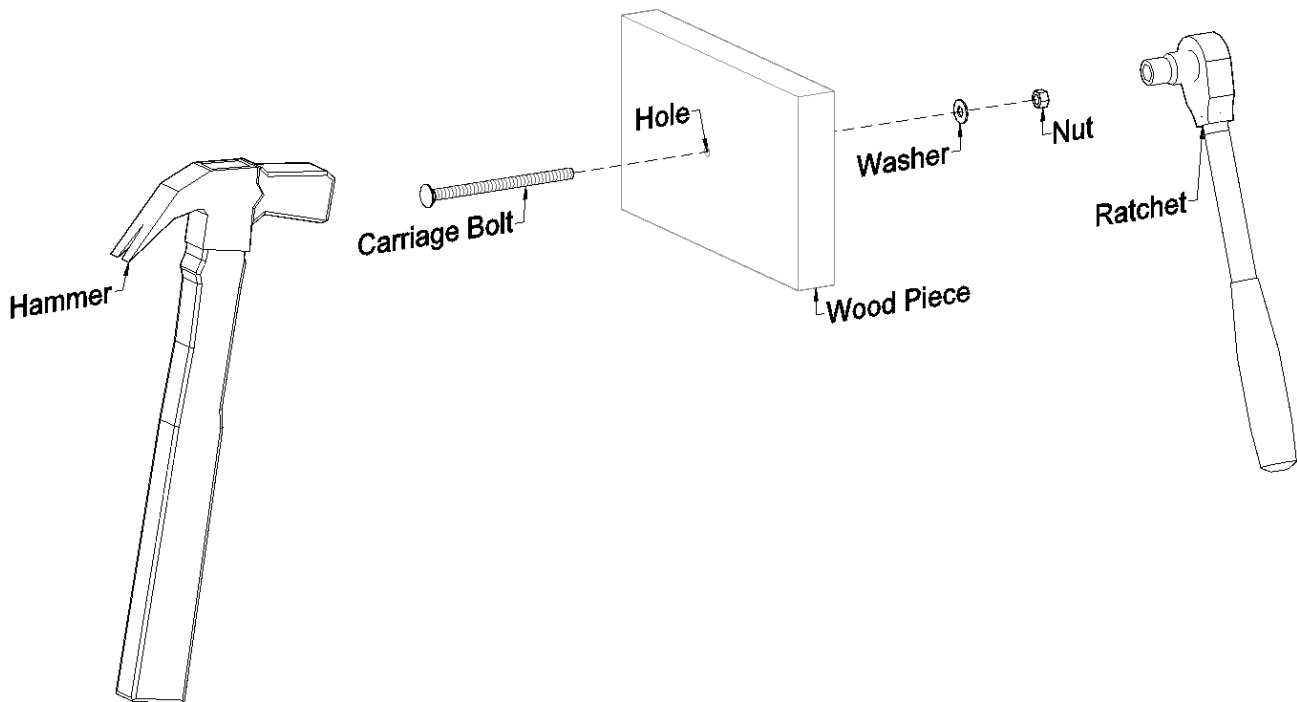

To install the bolts.

Insert the carriage bolts into the holes and lightly tap with a hammer until the square neck fit in the wood piece and the bolt head must flush with the wood piece. Finally, place the washer and the nut and carefully tighten it using a ratchet with the necessary socket or a wrench.

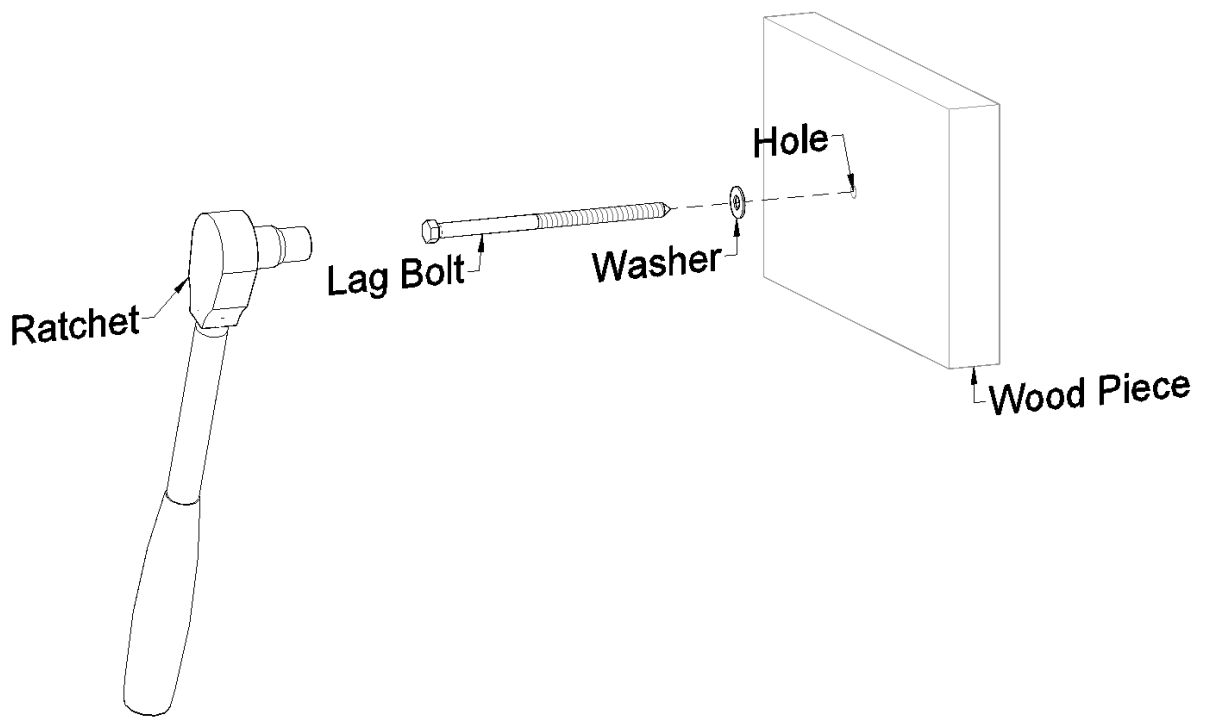

To install the lag bolts.

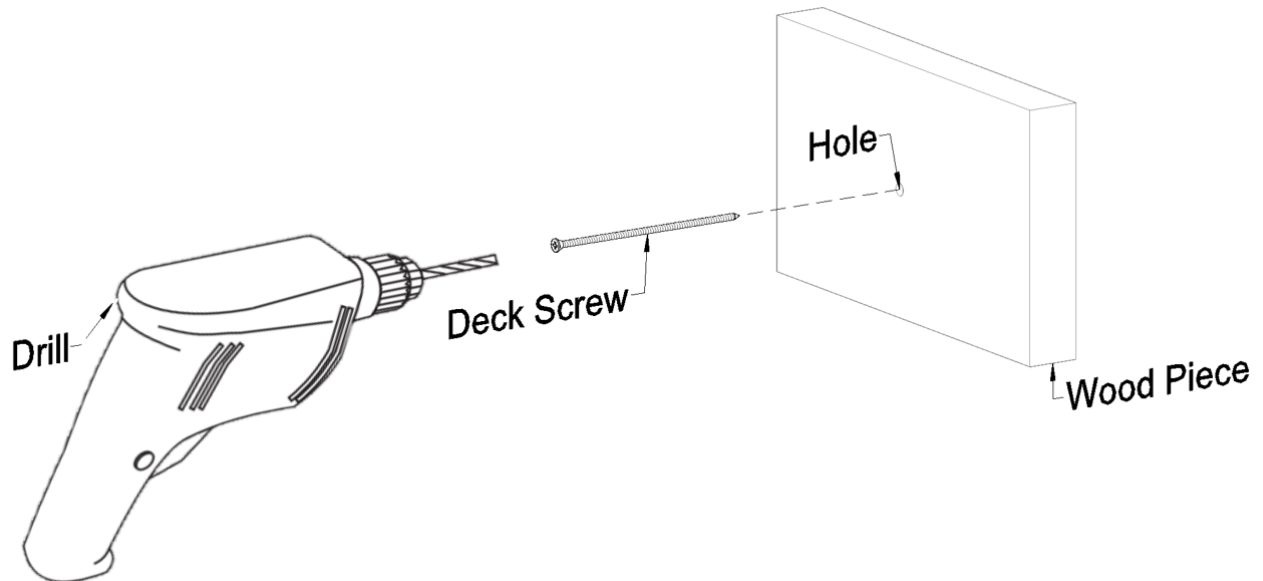

Place the washers in their lag bolts. After that, insert the lag bolts into the holes and carefully tighten it using a **ratchet** with the necessary **socket**.

Use the washers only for the Wood Pieces.



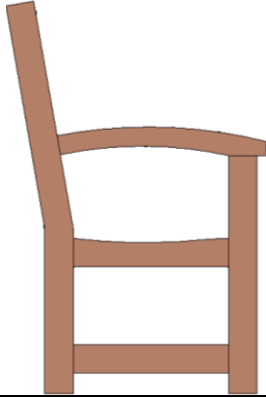
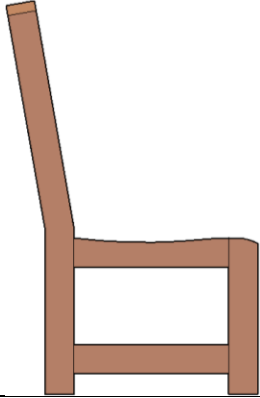
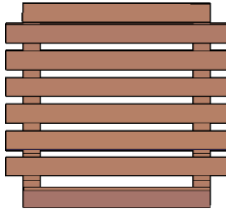
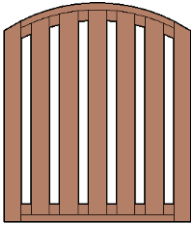

To install the deck screws.

Insert the deck screws into the holes and carefully tighten it using a drill.

CONTENT OF BOXES				
Qty.	Description	Drawing		No.
2	Legs (With arms or armless)			1
		With arms	Armless	
1	Seat			2
1	Backrest			3
1	Front support			4
2	Diagonal supports			5

Note: Part numbers in the Content of Boxes Table are for reference only. These do not match to the numbers marked on the parts sent.

HARDWARE LIST		
Description	Drawing	No.
5/16" x 3 1/2" bolts		BL1
5/16" x 4 1/2" bolts		BL2

Note: Dimensions of your hardware will vary depending on size.

DESCRIPTION	No.
Legs	1
Seat	2
Backrest	3
Front support	4
Diagonal supports	5

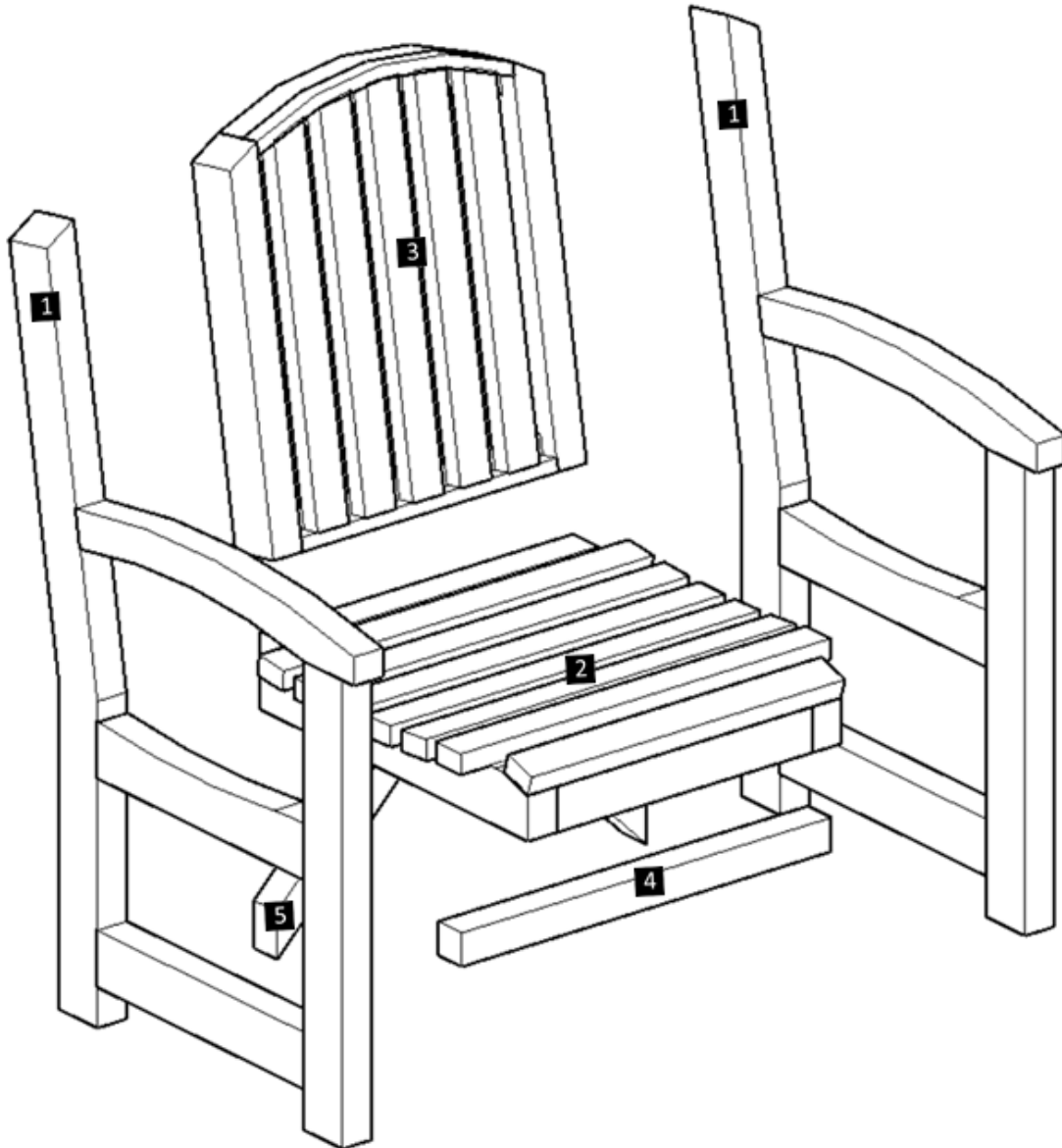

Note: Part numbers in the Drawing are for reference only. These do not match to the numbers marked on the parts sent.

Step 1: Use 5/16" x 3 1/2" bolts (**BL1**) to attach the legs (**1**) to the seat (**2**). Each part has a series of numbers that indicate where to attach the part with the corresponding number.

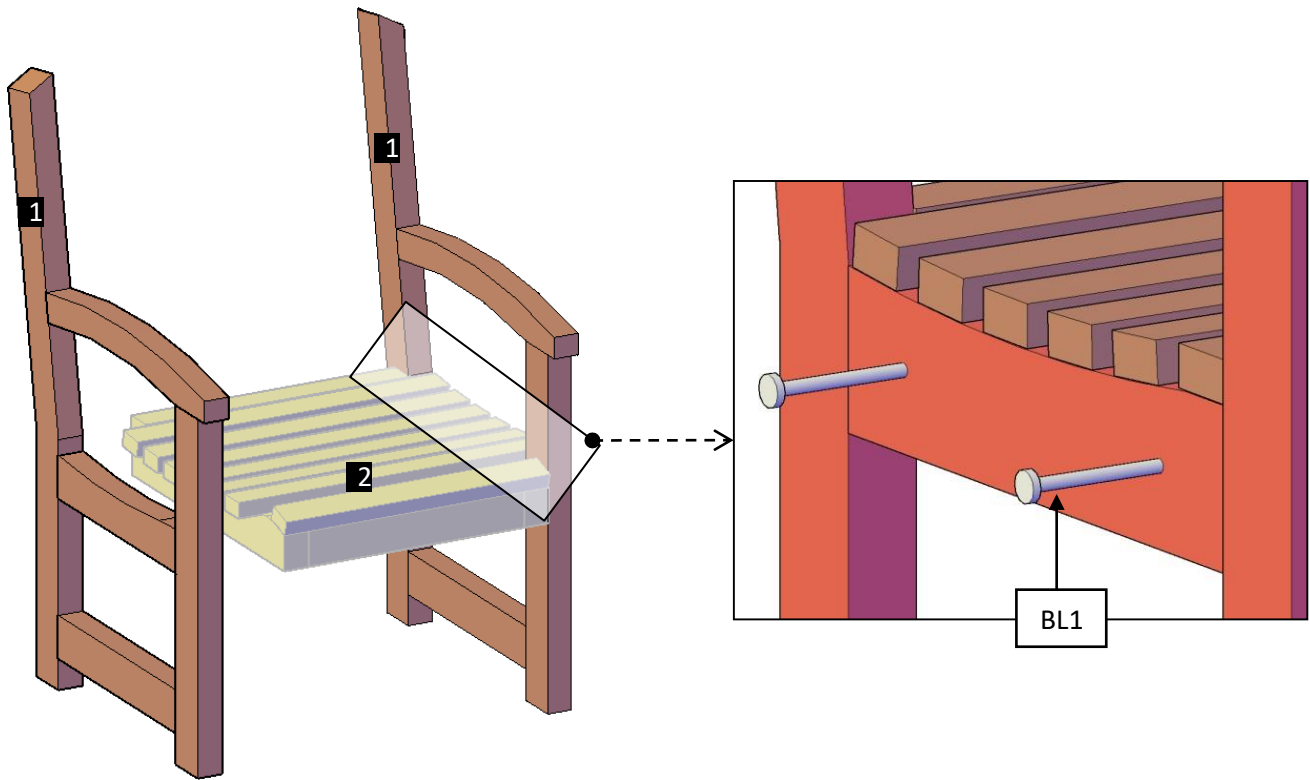

Step 2: Attach the backrest (**3**) to the legs with 5/16" x 3 1/2" bolts (**BL1**). Each part has a series of numbers that indicate where to attach the part with the corresponding number.

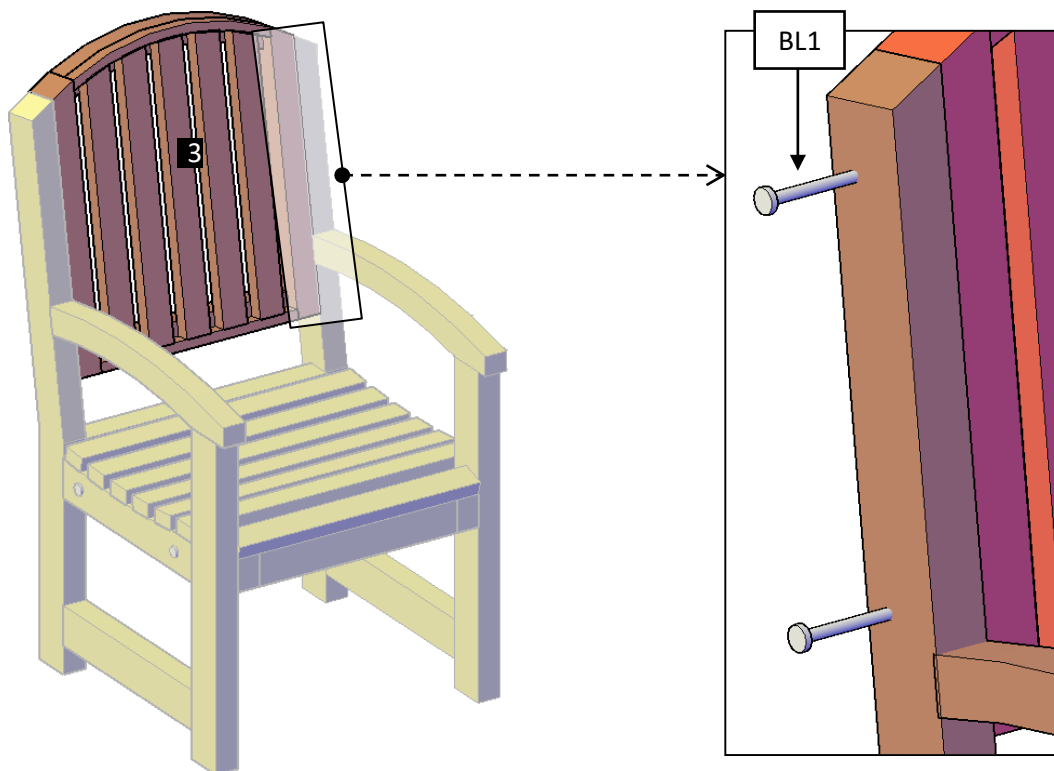

Step 3: Attach the frontal support (4) to the legs with 5/16" x 4 1/2" bolts (BL2). Each part has a series of numbers that indicate where to attach the part with the corresponding number.

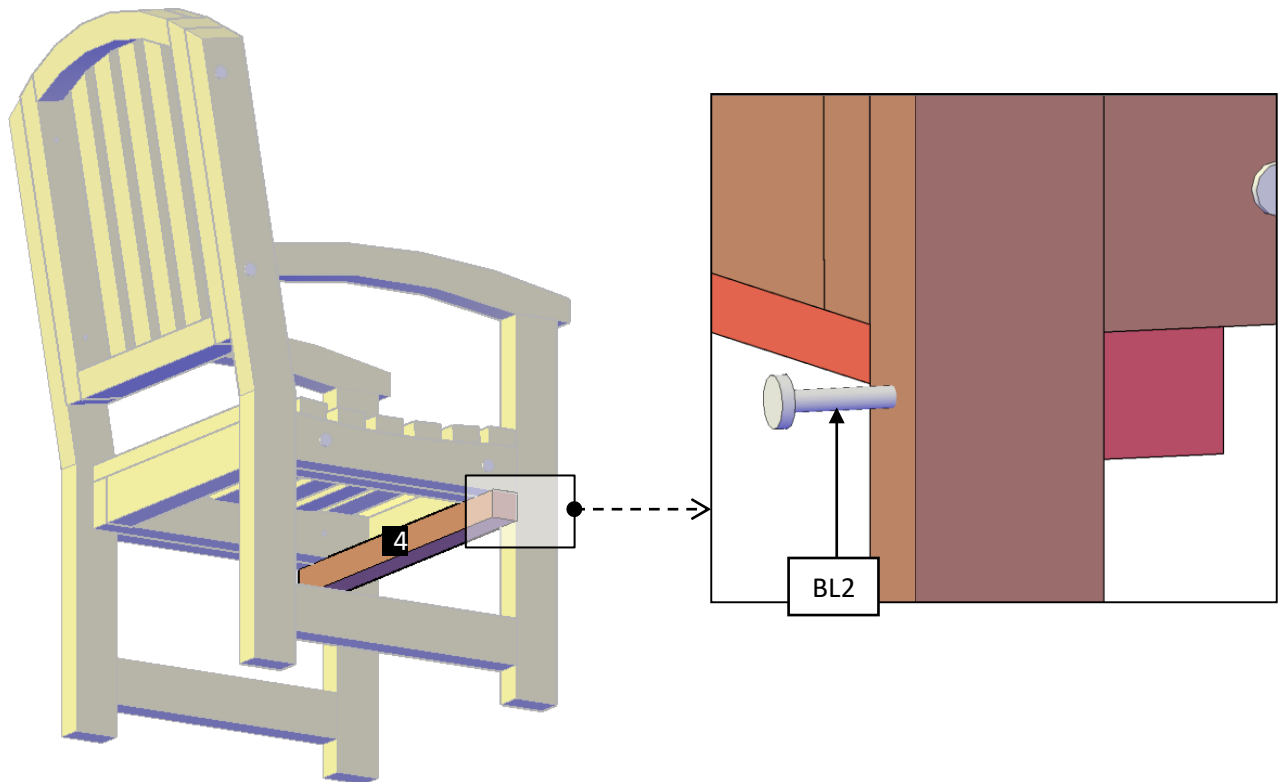

Step 4: Use 5/16" x 3 1/2" bolts (BL1) to attach the diagonal supports (5) to the seat. After that, use 5/16" x 4 1/2" (BL2) bolts to attach to the legs. Each part has a series of numbers that indicate where to attach the part with the corresponding number.

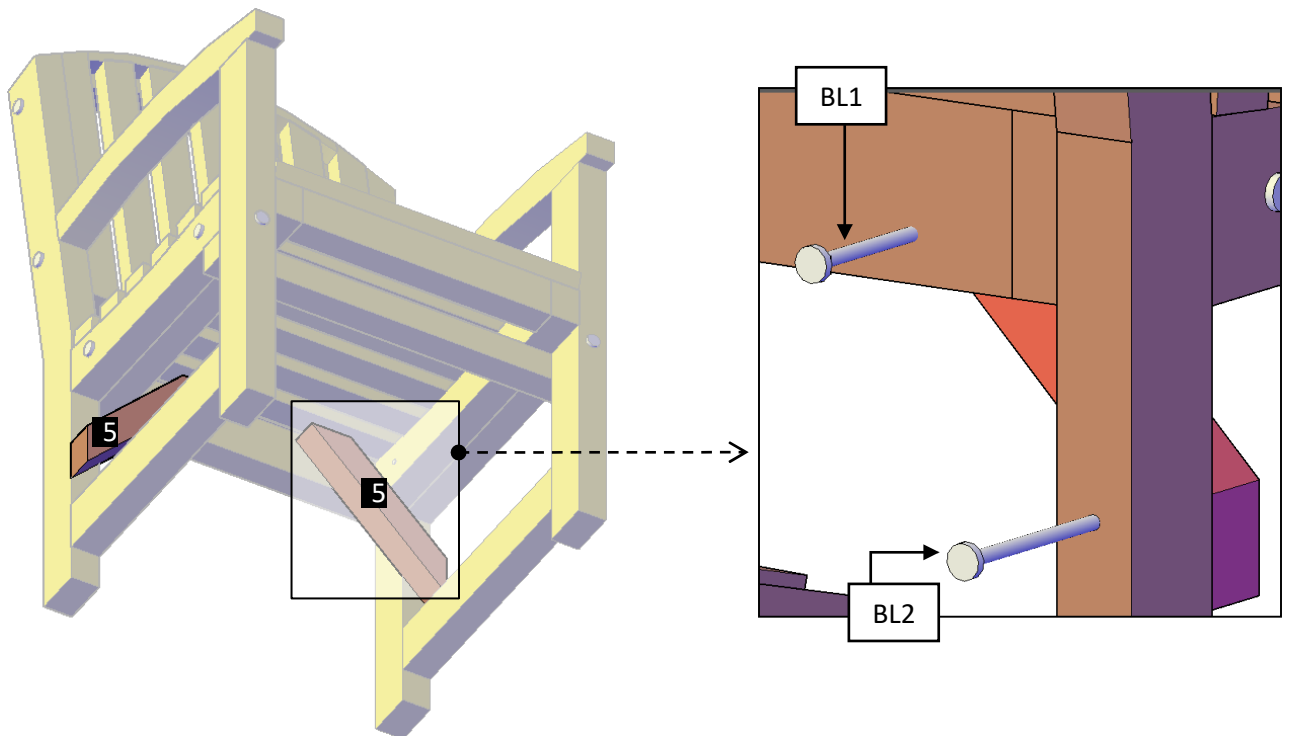

Luna Arch Back Wooden Chair – With Arms

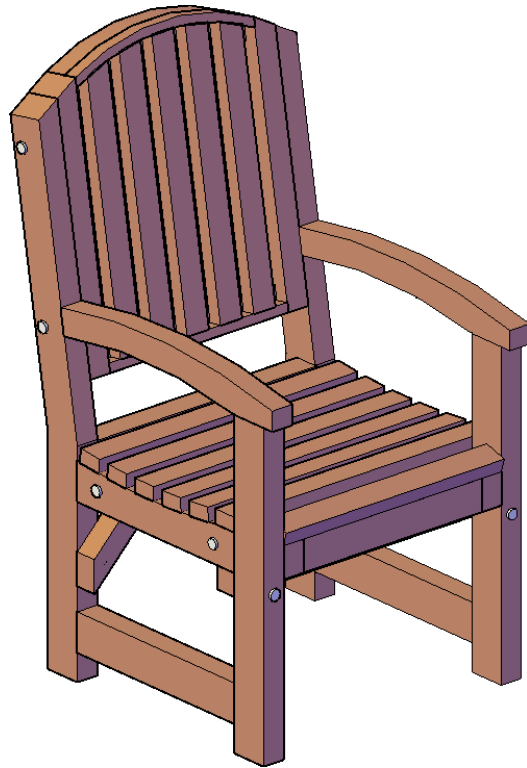

Luna Arch Back Wooden Chair – Armless

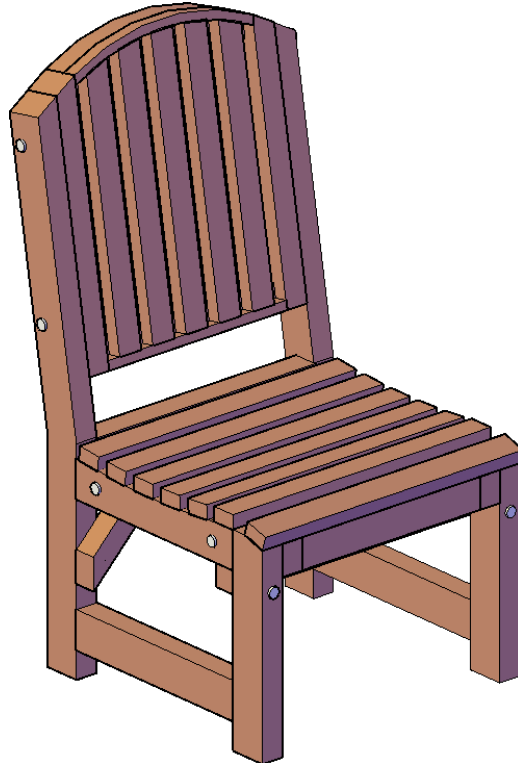



This completes the outdoor assembly. Hope you enjoy your set for many decades. If you ever have a problem or a question, don't hesitate to call us (866 332 2403) or email us. We are here to support you.