

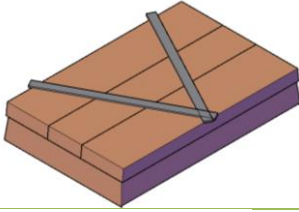

866.332.2403 (Toll Free); 7am-7pm Pacific Time, Monday-Saturday

Assembly instructions for: **REDWOOD RESTAURANT HIGH CHAIR**

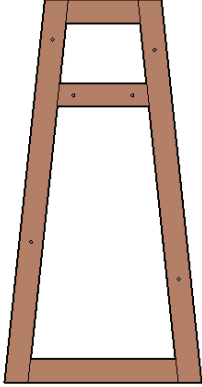
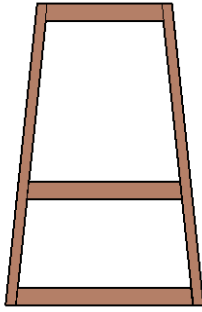
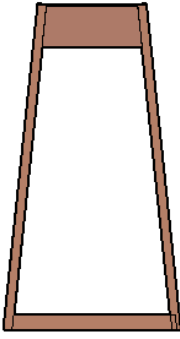

CONTENT OF BOXES

QUANTITY	DESCRIPTION	DRAWING	
1	Seat		
2	Legs		
1	Front support		
1	Backrest		
Depending on size	Hardware: Bolts and deck screws	Deck Screws 	Bolts, washers and nuts 

ASSEMBLY INSTRUCTIONS

Thank you for purchasing Forever Redwood patio furniture. Forever Redwood is built by Old Growth Again Restoration Forestry (OGA). OGA is dedicated to restoration forestry. Sales of patio furniture finance our restoration work in California redwood forestlands. Tools required: ½-inch ratchet and a mallet or small hammer.

Unpack your chair and make sure you have all the parts. The parts that go together have the same numbers written next to the predrilled holes they attach to. Align the parts with the numbers as shown for ease of reference.

Step 1. Attach leg to seat with 2 carriage bolts (2 ½" x 5/16), washers and nuts. On the edges of the seat you'll find a number written next to a set of predrilled holes. Match this number to the number written next to the predrilled holes on the interior edge of the center member of the side of the chair. Tap in the carriage bolts from the outside edge into the holes to attach the seat and leg. Tap the bolts in all the way, then insert the washer and nut and tighten with a ½-inch ratchet. The bolts should tap into their holes. If you have to force a bolt, the piece is probably on the wrong side or is turned around. Do not over tighten or you'll crush the redwood and weaken the bench's structure.

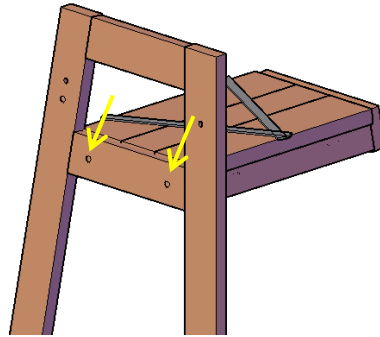

Step 2. Attach backrest to leg with 2 carriage bolts (1 ¾" x 5/16), washers and nuts. Match the numbers next to the predrilled holes on the backrest to the numbers on the chair side. Tap the carriage bolts all the way into the wood, then attach the washers, nuts and tighten with ½-inch ratchet. Do not over-tighten.

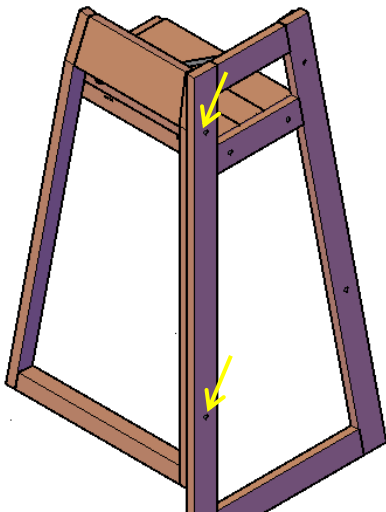

Step 3. Attach backrest and leg to seat with 4 carriage bolts, washers and nuts. Match the numbers next to the predrilled holes on the pieces. Tap the carriage bolts all the way into the wood, then attach the washers, nuts and tighten with ½-inch ratchet. Do not over-tighten.

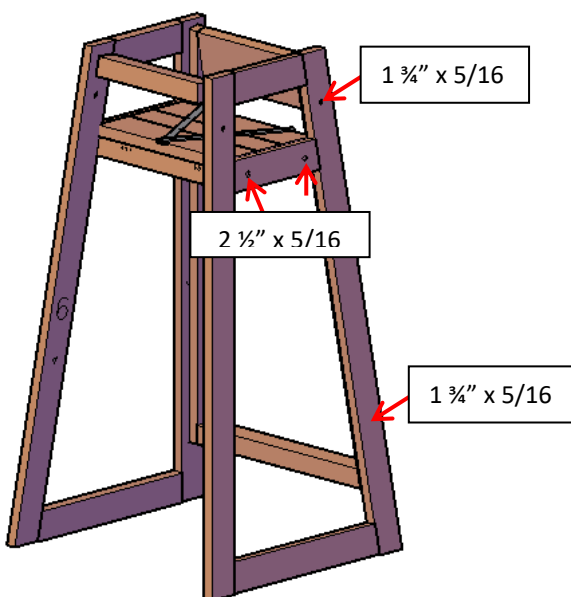

Step 4. Attach front support and leg to seat with 4 carriage bolts (1 ¾" x 5/16), washers and nuts. Match the numbers next to the predrilled holes on the pieces. Tap the carriage bolts all the way into the wood, then attach the washers, nuts and tighten with ½-inch ratchet. Do not over-tighten.

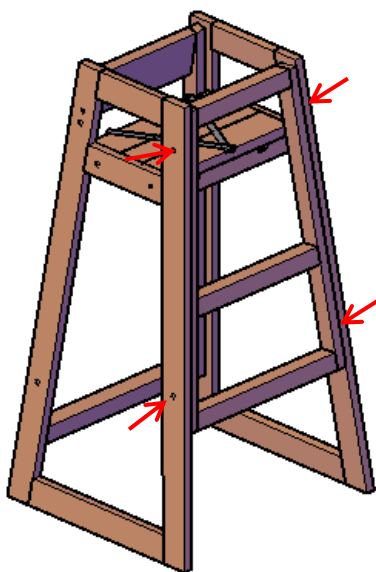

Thank you. If you have any questions, please call or email us.