



FOREVER REDWOOD

From the Forest, For the Forest since 1995



866.332.2403 (TOLL FREE); 7am – 7pm Pacific Time, Monday-Saturday

ASSEMBLY INSTRUCTIONS FOR THE **ROUND WOOD PICNIC TABLE WITH WHEELS**



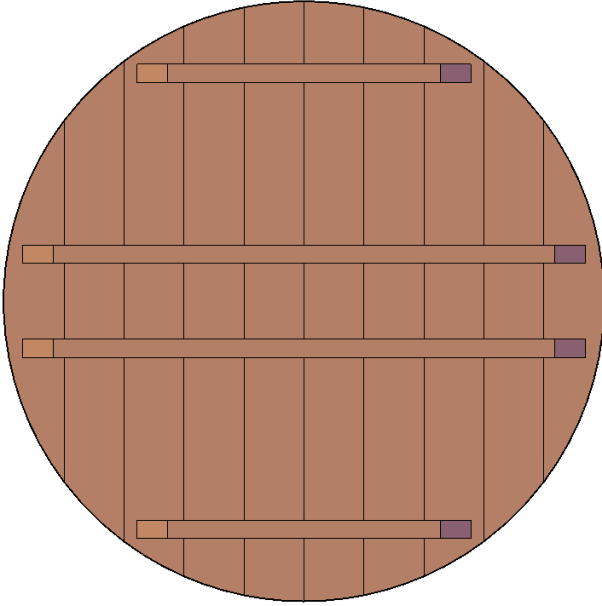
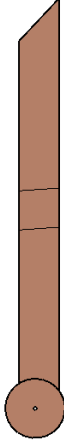

CONTENT OF BOXES

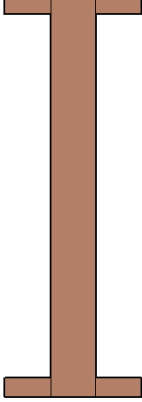
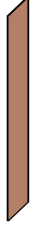
Qty.	Description	Drawing	No.
1	Tabletop		1
2	Legs with Wheels		2
2	Legs		3
1	Support		4
2	Diagonal Supports		5

Note: Part numbers in the Content of Boxes Table are for reference only. These do not match to the numbers marked on the parts sent.

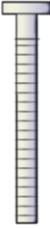
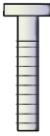

HARDWARE LIST

Description	Drawing	No.
5/16'' X 3 1/2'' Bolts (To attach the legs to the tabletop. / To attach the support to the legs. / To attach the diagonal supports to the tabletop and to the leg).		A
5/16'' X 2'' Bolts (To attach the legs together).		B

Note: Dimensions of your hardware will vary depending on size.



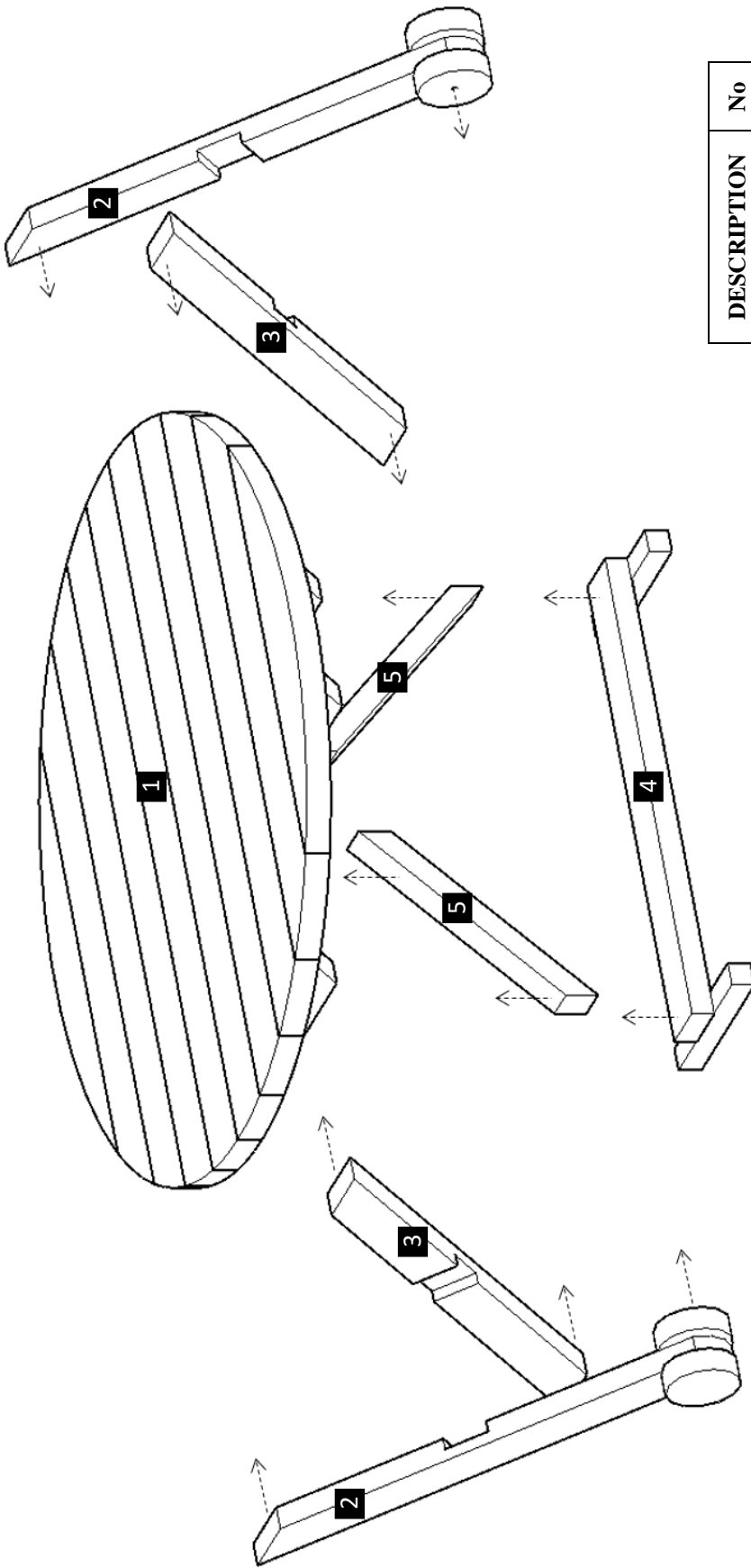

DESCRIPTION	No
Tabletop	1
Legs with Wheels	2
Legs	3
Support	4
Diagonal Supports	5

Note: Part numbers in the Drawing are for reference only. These do not match to the numbers marked on the parts sent.

Step 1: Place the Tabletop (1) upside down. After that, use 5/16" x 3 1/2" bolts (A) to attach the legs with wheels (2) to the tabletop. Each part has a series of numbers that indicate where to attach the part with the corresponding number.

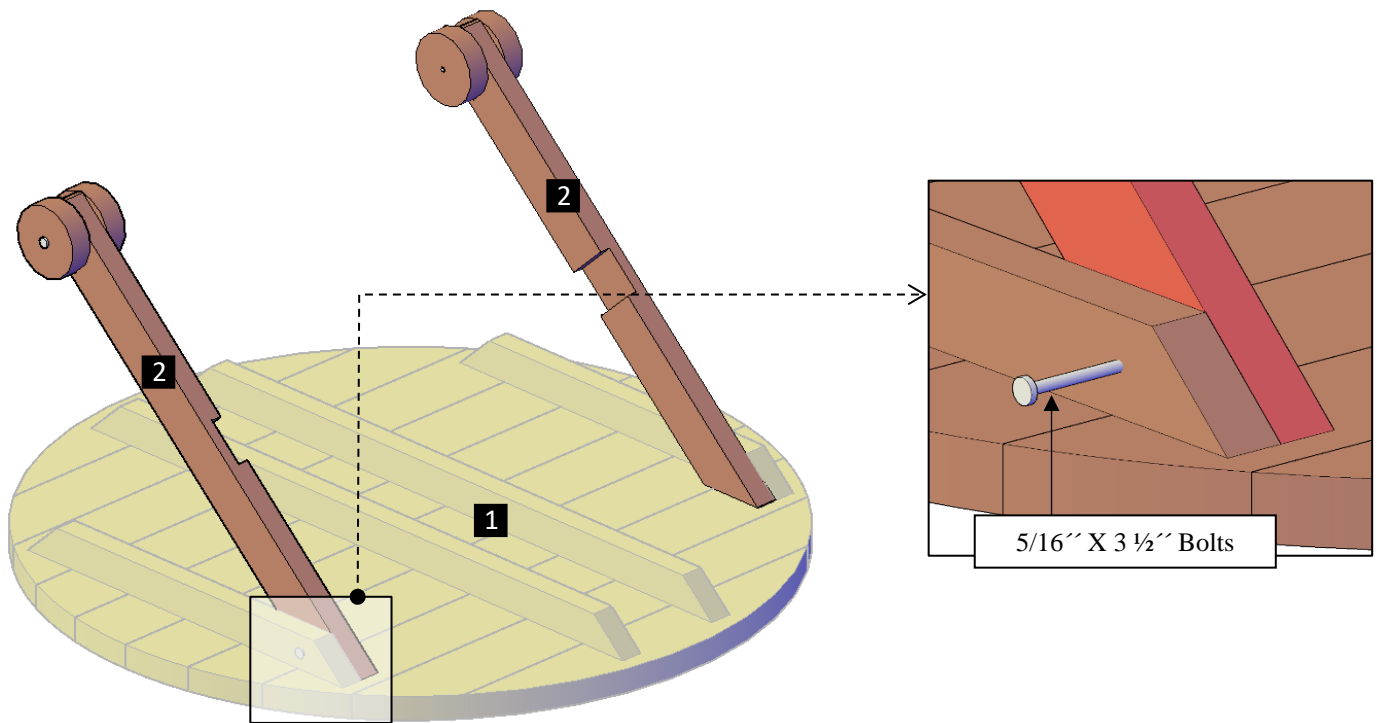

Step 2: Attach the other legs (3) to the tabletop with 5/16" x 3 1/2" bolts (A). The legs will be attached together with 5/16" x 2" bolts (B). Each part has a series of numbers that indicate where to attach the part with the corresponding number.

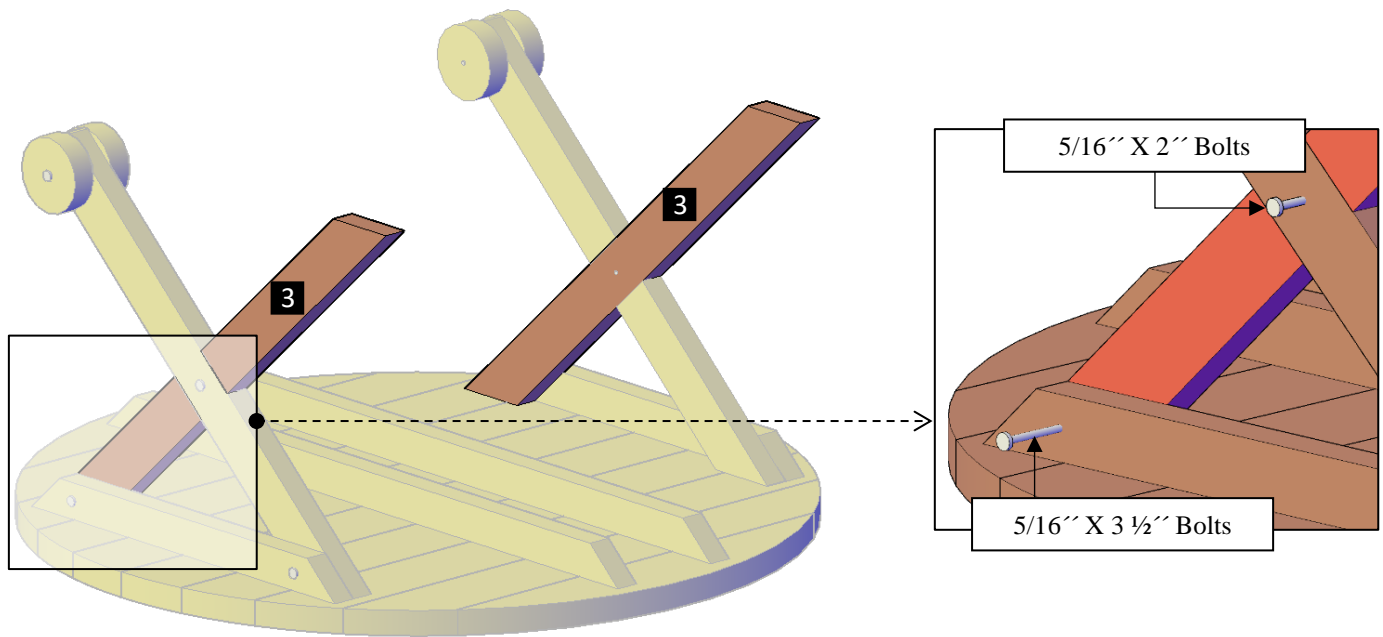

Step 3: Attach the support (4) to the legs with 5/16" x 3 1/2" bolts (A). Each part has a series of numbers that indicate where to attach the part with the corresponding number.

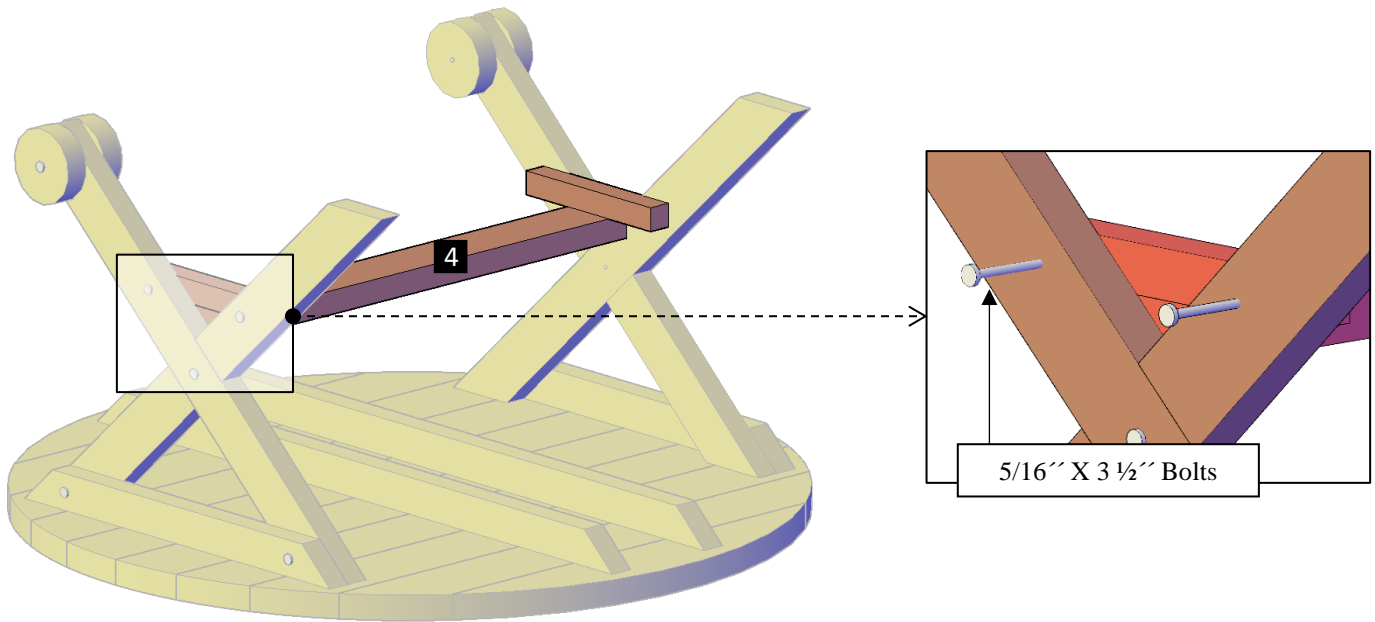

Step 4: Use 5/16" x 3 1/2" bolts (A) to attach the diagonal supports (5) to the tabletop and to the legs. Each part has a series of numbers that indicate where to attach the part with the corresponding number

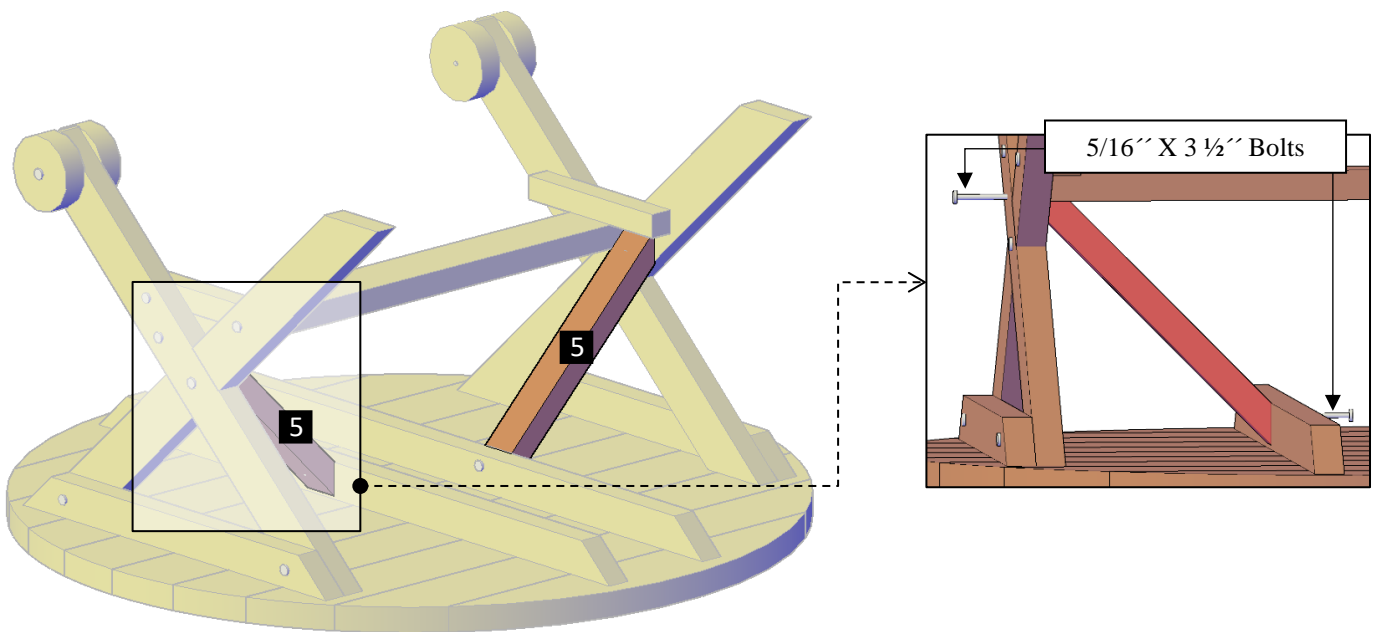

Step 5: Finally, turn the table over its feet.



This completes the Table assembly. Hope you enjoy your set for many decades. If you ever have a problem or a question, don't hesitate to call us (866 332 2403) or email us. We are here to support you.